



OPERATING MANUAL
HDX 2000 AUTOMATIC L-SEALER
SERIES B



READ ALL INSTRUCTIONS CAREFULLY BEFORE OPERATING EQUIPMENT

TABLE OF CONTENTS



Preface	3
Safety standards.....	4
Machine Installation	8
Machine Setup & Adjustments	14
Film Setup and Adjustments	34
Alarms & Troubleshooting.....	45
Maintenance & Cleaning	49
Notes	51

This manual gives instruction for the proper use of the machine. Keep it near the machine in a place that is known to all users. The manual is essential for safety.



The HDX-2000 is an automatic packaging machine designed to package loose pieces or groups of products using a center-folded heat-shrink film. A wide range of products with different shapes and sizes can be packaged with the HDX-2000.

The HDX-2000 can be fed manually or by means of an infeed conveyor or other machinery.

The HDX-2000 can be operated in "MANUL" or "AUTOMATIC" modes.

In "MANUAL" mode, it must be operated by a trained qualified operator.

In "AUTOMATIC" mode, the machine is controlled by a PLC.

	ATTENTION: Accident prevention rules for the operator. This warning indicates the presence of dangers which can injure the person operating the machine.
	ATTENTION: Hot parts. Shows the danger of burning, thus presenting the risk of a serious accident for the exposed person.
	WARNING: It indicates the possibility of damaging the machine and/or its components.

WARNINGS

It is extremely important to read this entire chapter as it contains important information regarding risks that personnel are subject to in the event of incorrect use of the machine. These basic standards must be observed as well as any other standards applicable in the location of installation.

- The machine must be installed by trained and authorized technicians.
- This machine is not intended for use by persons (including children) with reduced physical, sensory, or mental capabilities, or lack of experience and knowledge, unless they are under the supervision or instruction concerning use of the machine by a person responsible for their safety.
- Never use the machine for purposes other than as specified in this document.
- Never allow unauthorized personnel to perform repairs or other operations on the machinery.
- The operator must be familiar with all warnings related to the tasks at hand and always be informed by the head of the site regarding risks
- All clothing shall be tight fitting, with particular reference to cuffs or other loose clothing.
- All loose jewelry shall be removed when operating and/or working on the machine.
- Ensure that all operating areas and transit zones are kept clear, clean and adequately lit at all times.
- Eliminate all safety hazard conditions before using the machine and always notify appropriate personnel of any malfunction.
- Never use the machine in the event of fault.
- Never tamper with safety devices or circuits.
- Never perform modifications on the machine without prior authorization from the manufacturer.
- If the supply cord is damaged, it must be replaced by the manufacturer, its service agent or similarly qualified persons in order to avoid a hazard.
- The electrical enclosure must remain closed during operation.
- The key to open the electrical enclosure must be kept by an authorized member of personnel.
- Never perform maintenance and/or adjustments to the machine during operation. Guards may only be disassembled by suitably trained and qualified personnel.
- Never operate the machine without all guards in place. Ensure correct position of all guards before resuming normal operation.
- The manufacturer declines all liability for damage or physical injury caused by failure to observe safety standards.







CAUTION!



This machine is NOT designed for explosion-proof applications; it is a standard model and therefore must never be installed or operated in zones subject to the risk of explosion.

SAFETY STICKERS

The following safety stickers features on the machine

	<p>On machine front panel.</p> <p>Danger of electrocution!</p> <p>Risk due to presence of electrical power in electrical system inside panel.</p> <p>While the machine is running, the panel must be mounted properly.</p>
	<p>On the sealing bar frame.</p> <p>Hot surfaces!</p> <p>It shows the danger of burning, thus involving the risk of a serious accident for the exposed person.</p>
	<p>At the infeed and outfeed conveyor belt.</p> <p>Dragging hazard!</p> <p>Hazard generated by moving elements (conveyor belts, motor driven rollers) in the event of contact during operation.</p>
	<p>Danger of placing hands inside!</p> <p><i>Danger caused by placing hands in the product loading area on the infeed belt.</i></p>

INDIVIDUAL PROTECTION

	<p>Wear safety shoes that protect feet from impacts, crushing and compression while moving or handling the machine.</p>
	<p>Wear safety gloves that protect the hands from crushing and mechanical hazards and while moving or handling the machine.</p> <p>Wear safety gloves that protect the hands against the specific risks associated with the materials to be packed (mechanical, chemical) and against coming into contact with the high temperatures present on the seals and/or sealing blade (up to 200°C).</p>
	<p>Wear safety gloves that prevent the hands from coming into contact with food when packaging them.</p>

GUARDS

The machine is fitted with a front guard (C1) and two rear guards (C2) and (C3).

If one of these guards is opened, the machine stops.

The buzzer (P2) and the "Alarm" key on the display indicate that there is an alarm.

To reset machine operation, close the guards and press the RESET button

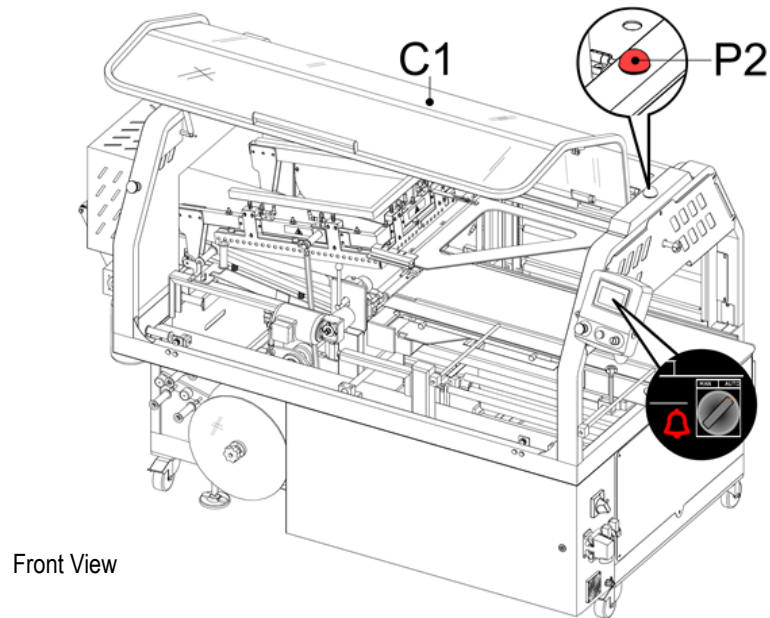

Front View

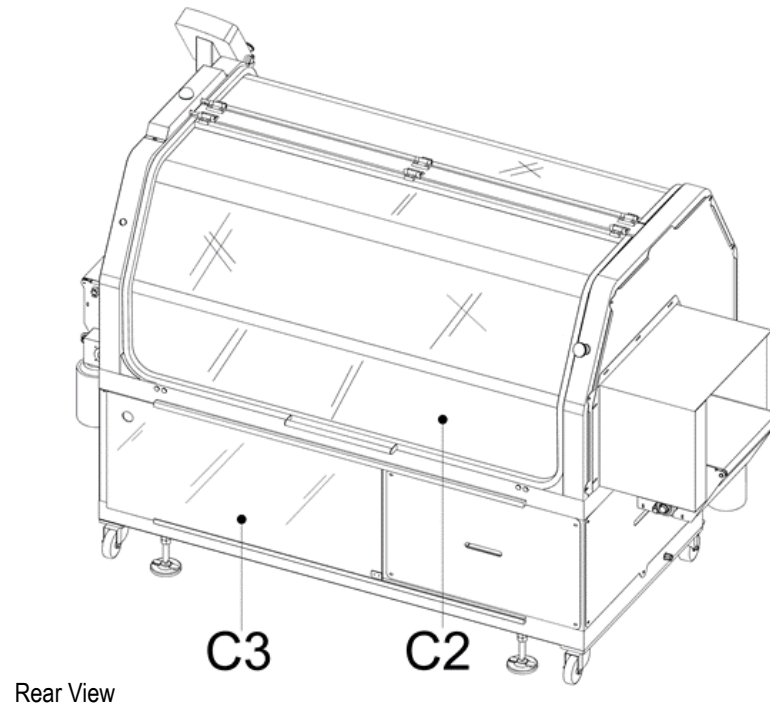



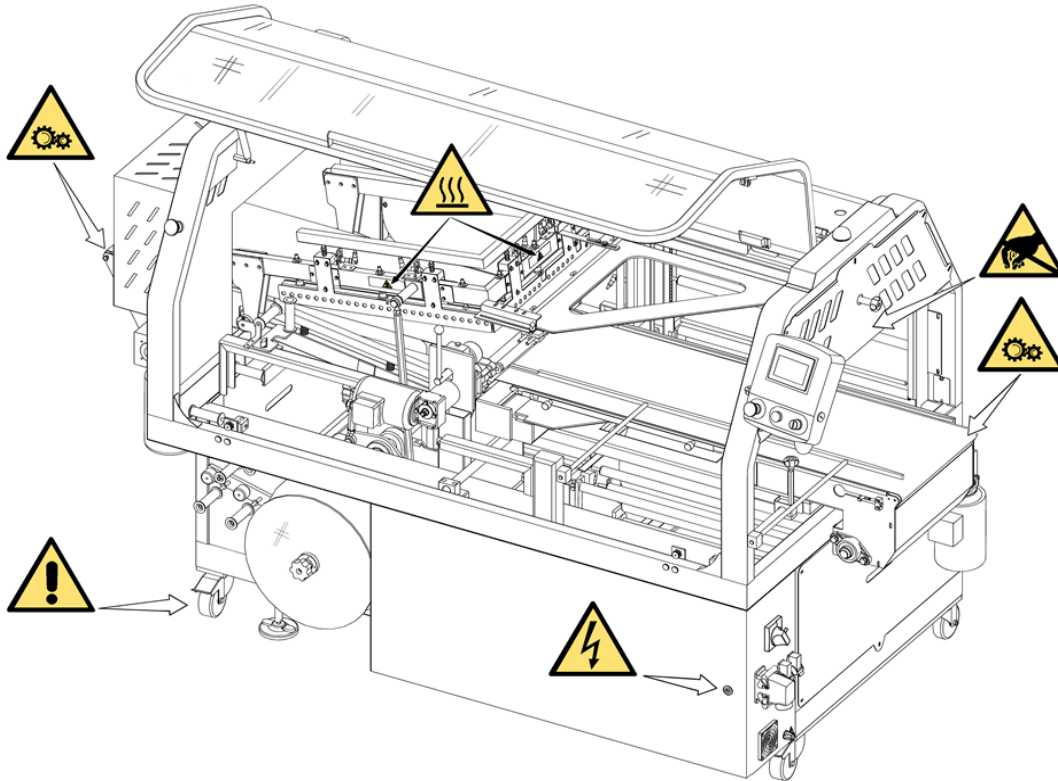

Rear View

RESIDUAL RISKS

The following prohibitions and warnings



	<p>Dragging hazard! Hazard generated by moving elements (conveyor belts, motor driven rollers) in the event of contact during operation.</p>
	<p>Burn hazard! <i>Risk due to high temperature of the sealing bar.</i> Do not touch the bar! Before performing operations in these zones, set the machine to “maintenance mode”, and wait for surfaces to cool. Never perform operations without suitable personal protective equipment such as gloves and overalls.</p>
	<p>Electric shock hazard! Electric Box and Panel: risk due to electric energy inside electrical control box. Before performing maintenance: <i>switch the machine off by rotating the main switch (Q1) to “0” (OFF)</i> <i>remove the plug from facility power source</i> <i>WAIT 15 minutes to allow the capacitors to discharge.</i></p>
	<p><i>The wheels must be used only for moving the unit short distances across smooth, horizontal floors.</i> Make sure the film reel is properly secured in place.</p>
	<p>Danger of placing hands inside! <i>Danger caused by placing hands in the product loading area on the infeed belt.</i></p>



INSTALLATION AND OPERATION OF THIS SYSTEM MUST BE IN COMPLIANCE WITH ALL APPLICABLE ELECTRICAL AND SAFETY STANDARDS. A QUALIFIED ELECTRICIAN MUST CHECK THE ELECTRICAL SUPPLY CIRCUIT TO ENSURE CORRECT VOLTAGE AND CAPACITY. THE SYSTEM IS DESIGNED FOR INDUSTRIAL USE BY QUALIFIED PERSONNEL ONLY.

- A dedicated 208V-240V single phase circuit is required to operate the unit. Amperage will depend upon the supply voltage, contact Heat Seal for details. The power cord for the system is shipped without a plug on it. The electrician or service person will have to install the proper plug to match the facility receptacle or hard wire the power cord into a wall mounted box to meet local electrical codes. In order to meet UL 508A standard, an Input Power Disconnect must be installed by a certified electrician with the machine. The Input Power Disconnect is an a factory installed option.

UNPACKING THE SYSTEM

- The HDX-2000 system is a unitized automatic shrink wrapping machine.
- Once the system has been unpackaged, check the system for any damage or missing parts. For your convenience, a wiring diagram is packaged with your unit. Heat Seal is not responsible for damage once the equipment has left our factory. Report any damage to your distributor and the shipping company. If there are missing parts, contact your distributor immediately.

ENVIRONMENTAL CONDITIONS

- Install the machine in an environment that is free from humidity, combustible materials, gas, and explosives.
- Install on a flat surface. Level machine before operation.
- Allow for 3ft, (1m), of clearance around machine.
- Working temperature range: 5-40 °C, (41-104°F)
- Relative humidity: 30%-90%, without condensation

MACHINE INSTALLATION



MACHINE LAYOUT

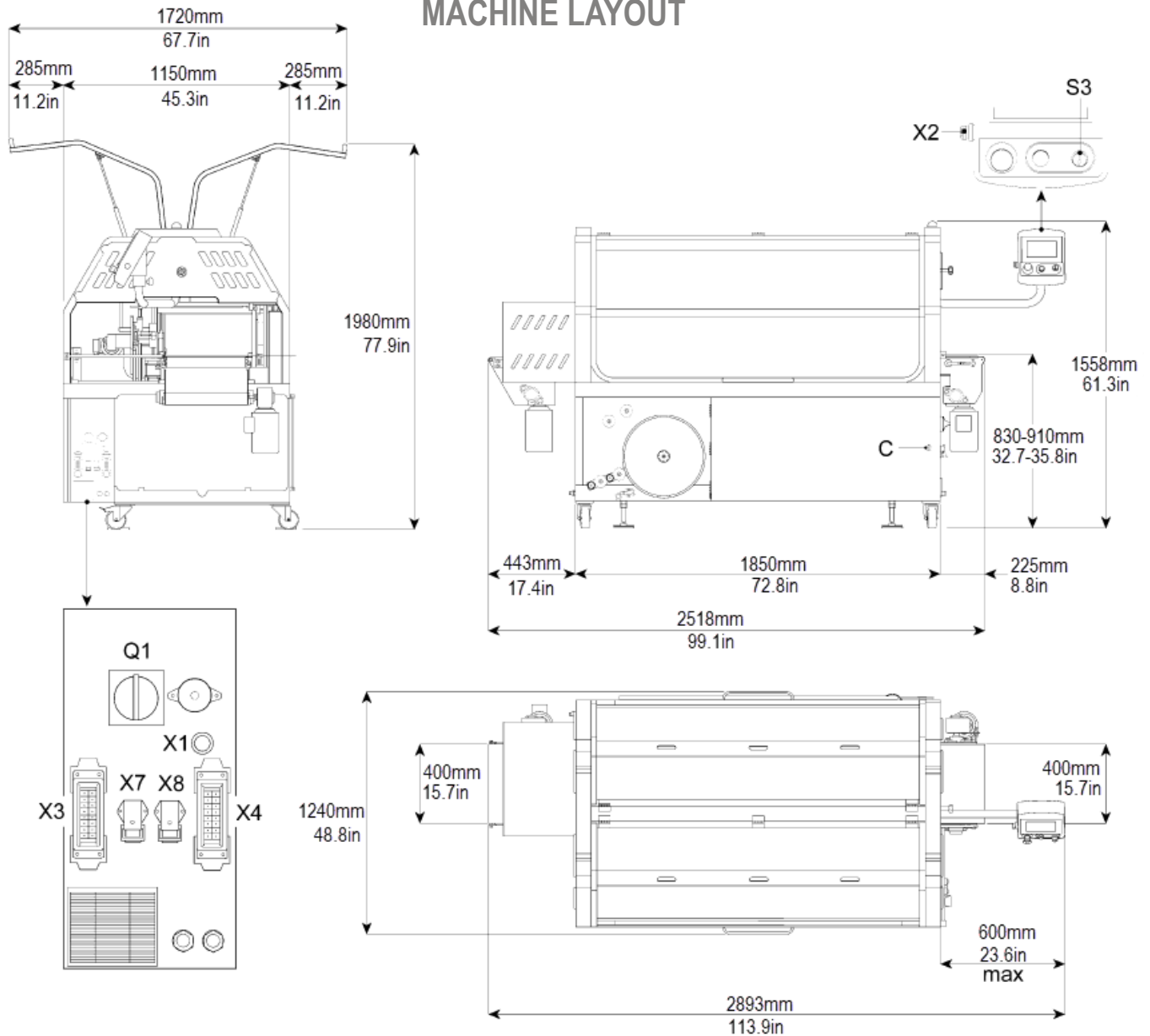



- C: Electrical control panel
- Q1: Main switch
- S3: "SAFETY OVERRIDE" switch
- X1: RJ45 socket for PLC and HMI Ethernet connection
- X2: USB connector
- X3: External infeed conveyor connector
- X4: External outfeed conveyor connector
- X7: Upstream control connector
- X8: Downstream control connector

MACHINE INSTALLATION



Technical Data	Metric	English
Package Size	2980x1530x2000 (mm)	117x60.2x78.7
Package Weight	797 (kg)	1757 lb
Machine Weight	645 (kg)	1422 lb

Transport and Positioning

	Wear safety shoes that protect feet from impacts, crushing and compression while moving or handling the machine.
	Wear safety gloves that protect the hands from crushing and mechanical hazards and while moving or handling the machine.
	<p>The machine must be installed by personnel who are qualified for this operation: personnel specifically trained to safely carry out the loading, unloading and handling operations, who are familiar with the accident prevention rules.</p> <p>Where a forklift must be used, please note that:</p> <ul style="list-style-type: none"> • The forklift truck must only be driven and manoeuvred by specialised and trained personnel who have the skills to carry out these activities, • the load to be handled must not exceed the capacity of the forklift, • the load to be handled must be stable and positioned in absolute safety.

Accessories

Check the following is included with the machine:

- 2 Keys for the SAFETY OVERRIDE switch, (S3)
- 1 Key for the electrical box (C)
- (4) Levelers (B)
- Electrical Schematic
- 1 Film opening rod, 10mm Dia, 730mm Lg, (A1)
- 1 Film opening rod, 10mm Dia, 730mm Lg, (A2)
- 1 Film opening rod, 8mm Dia, 572mm Lg, (A3)

Installing the levelers

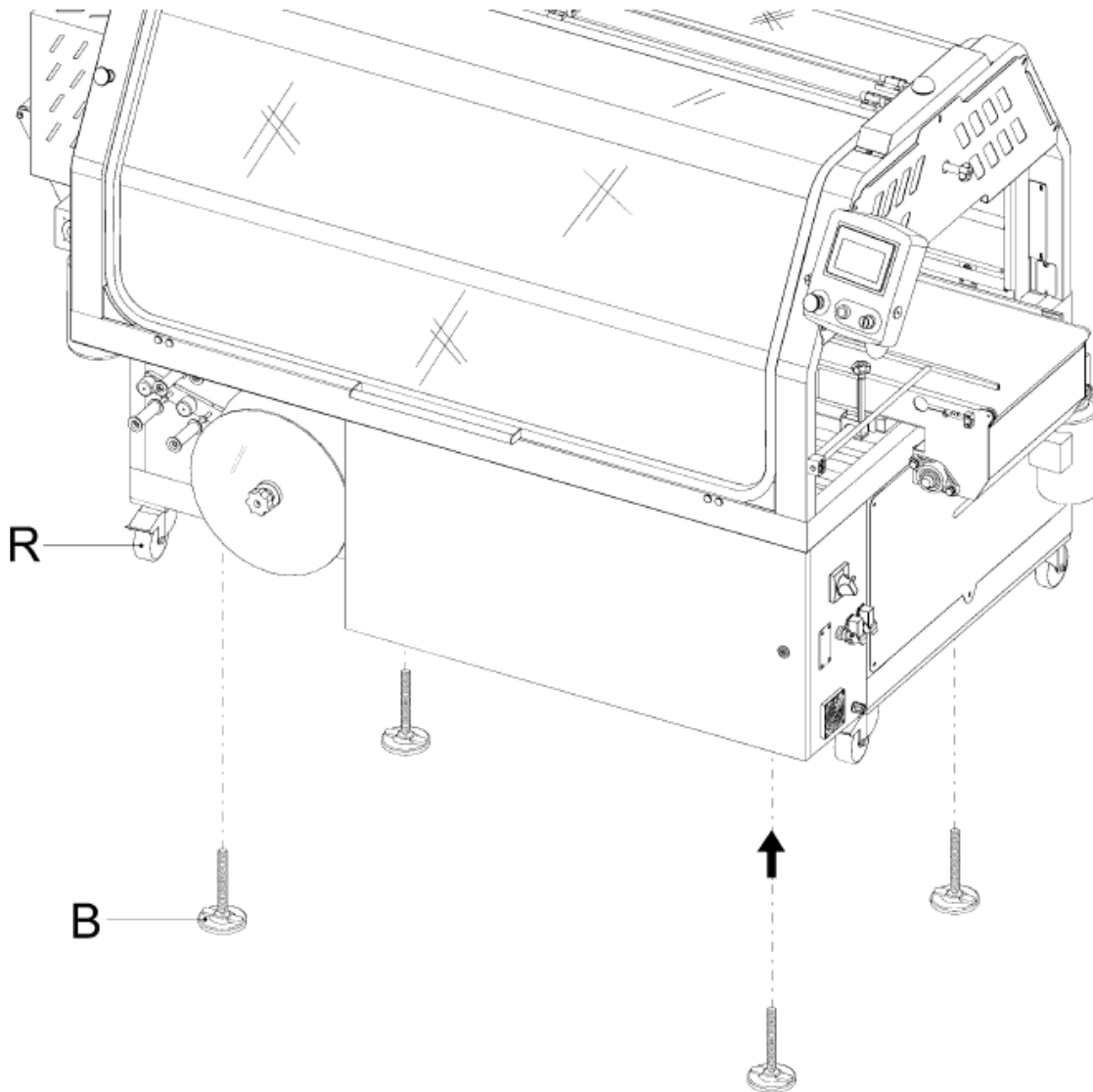

- Lift the machine from the pallet by using a fork lift.
- Install 4 levelers by threading into holes in frame until hand tight.
- Lower machine to floor and adjust leveler to place machine at desired height.
- Casters should only be used when moving the machine and not during operation.
- **THE MACHINE MUST ONLY BE OPERATED WHEN SUPPORTED BY LEVELERS**

Installing the film opening rods

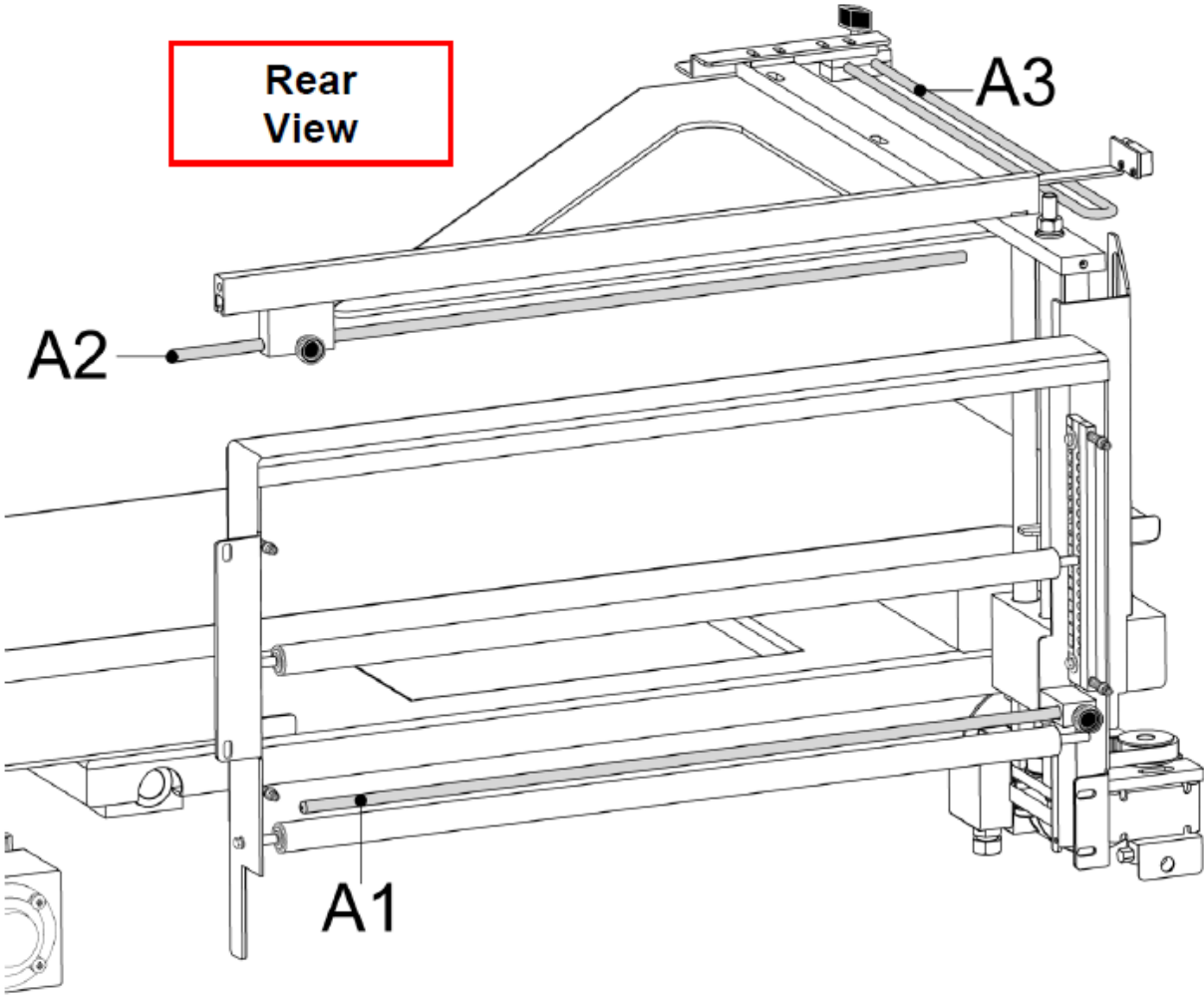

Electrical connections

Voltage: 208-240 VAC, single phase

Frequency: 50/60 HZ

Max Power: 2.5 kW

Full Load Amps: 11

	<p>The power line must be protected with a type B residual current device with rated residual current equal to "IΔn", 30 mA.</p> <p>As a result, the maximum resistance of the earth electrode must correspond to the values indicated in the following table</p>
---	---

I Δ n	Maximum resistance of the earth electrode	
	(50 V)	(25 V)
3 A	16 Ω	8 Ω
1 A	50 Ω	25 Ω
500 mA	100 Ω	50 Ω
300 mA	166 Ω	83 Ω
30 mA	1666 Ω	833 Ω

	<p><u>OBSERVE HEALTH AND SAFETY REGULATIONS!</u></p>
---	---

If the machine is not equipped with the power supply plug, use a plug that is suitable for the voltage and amperage values described by the rating plate and that can comply with the rules in force in the installation country.

GROUNDING OF THE UNIT IS OBLIGATORY!

Before executing electrical connections, make sure the mains voltage matches the one on the plate on machine rear and that the ground contact complies with the safety rules in force. In case of doubts about the mains voltage, contact the local public supply Company.

Insert the plug on the cable from machine electrical cabinet in a mains power supply socket that can be reached easily by the operator.

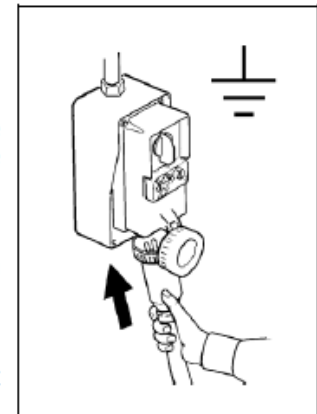

MAIN MACHINE COMPONENTS

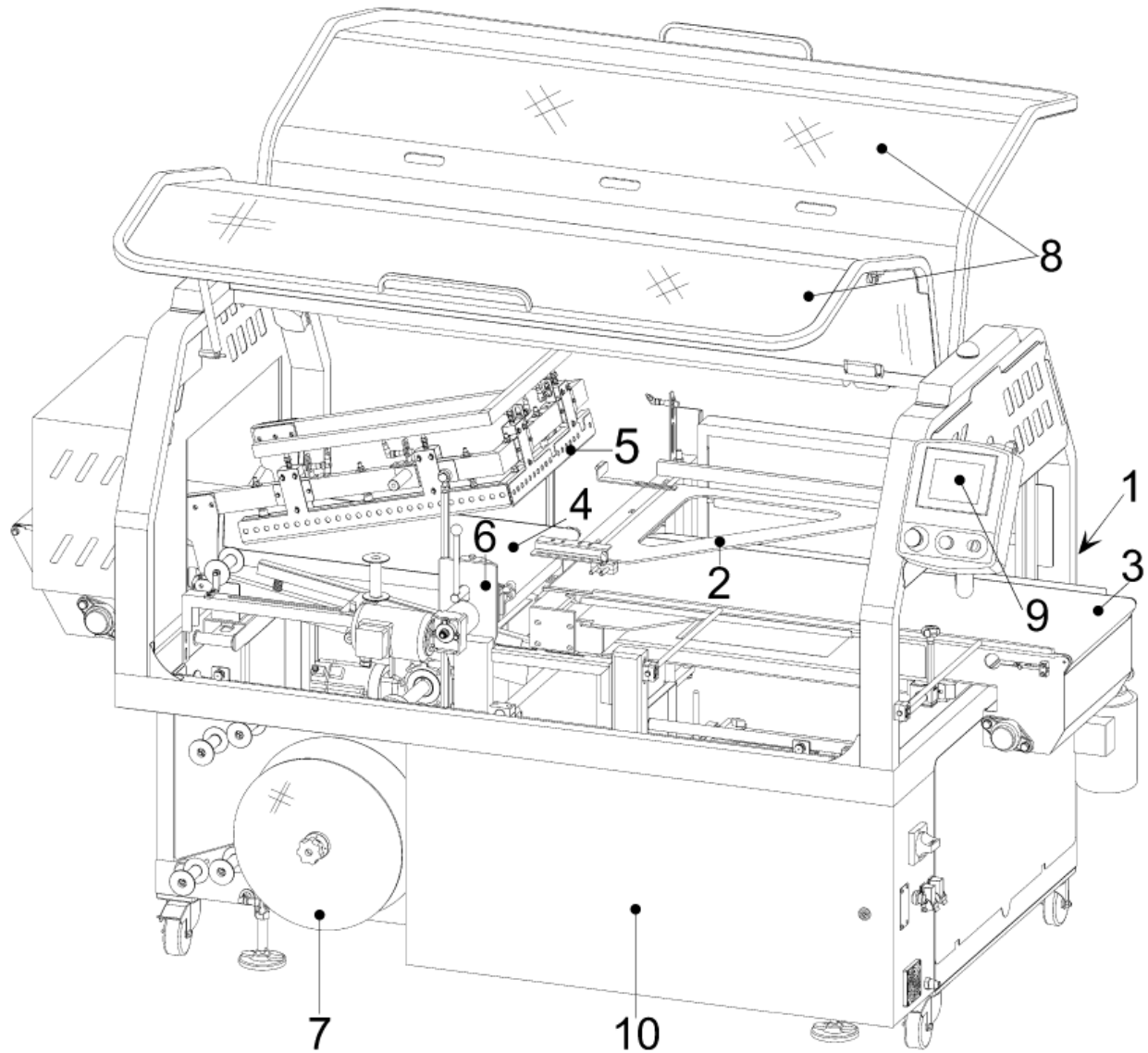

1. Film Unwinder
2. Film Inverter
3. Infeed Belt
4. Outfeed Belt
5. L-Sealer
6. Film Puller
7. Scrap Film Winder
8. Door Guards
9. Operator HMI
10. Electric Control Box/Panel

MACHINE FEATURES

The HDX-2000 is an automatic packaging machine designed to package loose pieces or groups of products using a center-folded heat-shrink film. A wide range of products with different shapes and sizes can be packaged with the HDX-2000.

The HDX-2000 can be fed manually or by means of an infeed conveyor or other machinery.

The HDX-2000 can be operated in "MANUL" or "AUTOMATIC" modes.

In "MANUAL" mode, it must be operated by a trained qualified operator.

In "AUTOMATIC" mode, the machine is controlled by a PLC.

The machine is equipped with a device for the recovery of scrap film, to avoid the presence of waste film inside the operator work zone.

Primary Features:

- An L-Sealing System with "Center Sealing" device that executes a seal with horizontal closing, mid product
- A system that brings the belts together in the sealing area. Ideal for packaging small size products
- Brushless Servomotor that controls sealing unit movement. Greater sealing precision and high productivity speed
- Maximum Production: 3600 (Package/Hour), subject to product size
- Due to the Double Guard and the Control Panel, Adjustable by 180°, the HDX-2000 can be operated from the front or rear of the machine, allowing the machine to be installed in a right to left or left to right production flow.

CONTROL PANEL





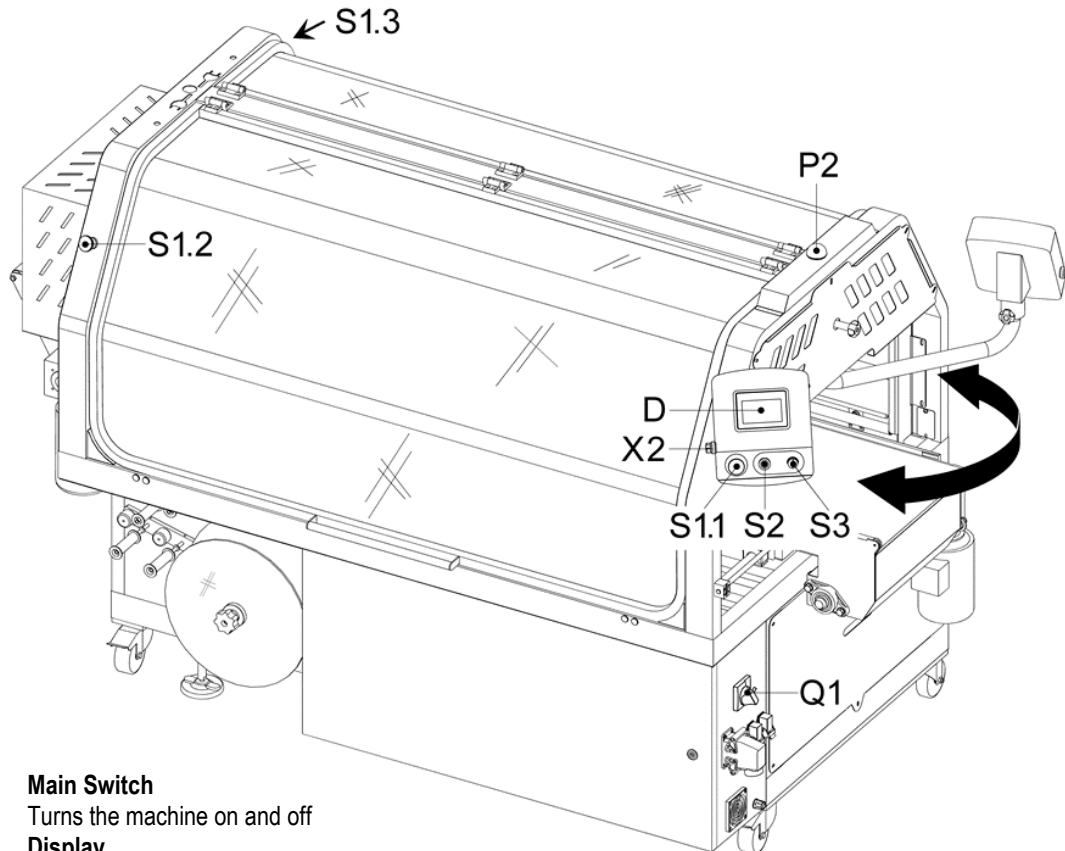



















This machine is equipped with an touch screen control panel adjustable by 180°, where it is possible to set all operation and programming features

 Only use one finger to select an object on the panel for correct touch panel use. If the panel is pressed in two or more points at the same time it is possible to select an object unintentionally.







- Q1 Main Switch**
Turns the machine on and off
- D Display**
Displays selected functions and relative settings
- S1.1 EMERGENCY Button**
- S1.2** These 3 buttons immediately stop the machine in case of immediate danger or to “place it in maintenance mode”.
- S1.3** If they are pressed, turn clockwise to release.
- S2 “RESET” Button**
Press on machine start-up and every time after E-stop or some faults
- S3 “SAFETY BYPASS” Switch**
If this selector switch is set to OFF, the machine may only be operated if the guards are closed (AUTOMATIC mode)
If this selector switch is set to ON, The machine may be operated with the guards open. This condition is necessary only when carrying out the set-up procedures and when inserting or changing the film reel (MANUAL mode only)
- X2** USB Connector for data transfer to the panel
- P2** Buzzer
Light/sound signal identify the machine status at any time

MAIN BUTTONS AND ICONS

Button	Description	Button	Description
	Select recipe		Alarm siren switch off
 	Recipe quick load		Save recipe
 	Start / Stop cycle		Load recipe
 	Automatic / Manual		New recipe
	Alarm		Delete recipe
	Set up		Load recipe from USB
	Conveyor belt movement and execution of film pulling/winder/unwinder		Save recipe on USB
	Sealing		Recipe list
	Batch counter		Wait for the operation to finish (sealing bar homing, data saving, etc.)
	Logout		Info
	Main (home page)		

BUZZER

Machine status	Light	Sound
The machine is ready	 Flashing green (at a frequency of 1 s)	No
The machine is homing the triangle	 Flashing green (at a frequency of 0.5 s)	No
The machine is in operation	 Steady green	No
The emergency button has been pressed	 Steady red	Yes
The machine is in alarm mode	 Flashing red	Yes

MACHINE SETUP & ADJUSTMENTS **HEATSEAL** with minipack®

START UP

Turn the main switch (Q1) to ON

The display comes on and the Logo screen appears



Press the "RESET" (S2) Button, then the Logo

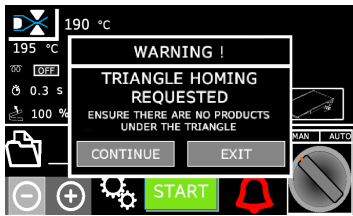

Triangle homing is required at every start-up (this is recommended when packing batches of products with different heights).

Press to run homing.

Press to not run homing.

DISPLAY

Home Page

The home page is split into various areas, each one of which can be used to view and/or edit parameters and functions

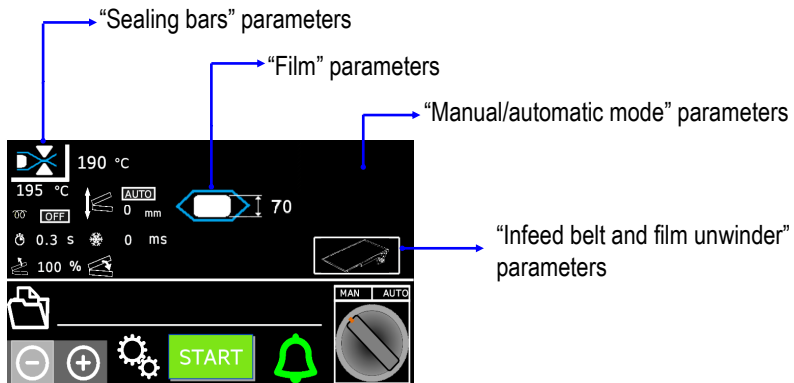

- Select recipe button
- Recipe quick load buttons
- Cycle start/stop buttons
- Automatic Button
- Manual Button
- Alarms Button
- Set-up Button

LANGUAGE SETTING

To choose the language used on the display screen follow the procedure described below.

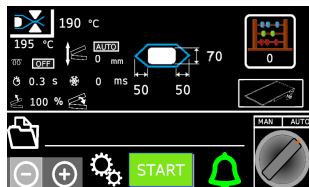

Press



Press

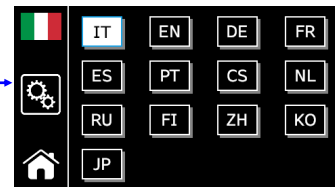

It displays the list of available languages:

Press the button that corresponds to the desired language, then press





HOW TO USE THE MACHINE

This machine can operate in 2 modes: **MANUAL** and **AUTOMATIC**

MANUAL MODE

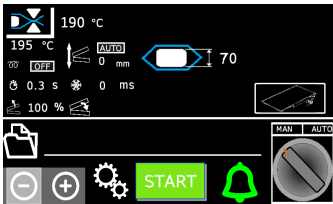
Upon power up, the machine is in Manual Mode by default



Press  to enable Manual mode.

To enable Manual program controls, press the

 start cycle button.

The screen will now display the “sealing” and “belt movement” controls.

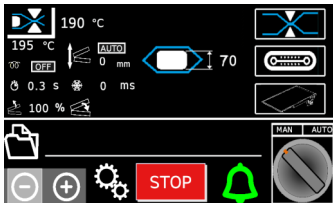

Sealing

By pressing this button, a sealing cycle is performed.

Belt movement



When pressed, it moves the infeed belt, sealing belt, pulling film, film unwinder and film rewinder for the entire time the button is held down.



MANUAL mode is required for the set-up and film roll installation/routing.

In this phase, it is possible to open guards (C1) and (C2) by turning on the Safety Bypass switch,(S3).

By turning the Safety Bypass switch (S3) to the OFF position, the alarm is reset.

With the guards open (after pressing the start cycle button ), only  is active.

AUTOMATIC MODE

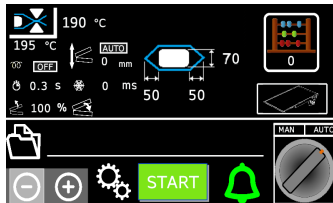

Press  to enable Automatic mode.

Press the start button  to start the automatic cycle.

DATA ENTRY KEYBOARD

The keyboard is displayed when the value of variable needs to be entered or changed.



PASSWORD

Some functions are password protected to guarantee correct operation of the machine and to prevent the operator from accidentally modifying the PLC program which controls all operations.

There are 3 password levels, each of which is protected by a different User Name and Password.

- Operator (First Level)
- Maintenance Technician (Second Level)
- Factory (Third Level)

The "Padlock" symbol next to a button indicates that the function is Password Protected.

"OPERATOR" PASSWORD (FIRST LEVEL)

With this password enabled, changes can not be saved to recipes.



"MAINTENANCE TECHNICIAN" AND "FACTORY" PASSWORDS (SECOND & THIRD LEVELS)

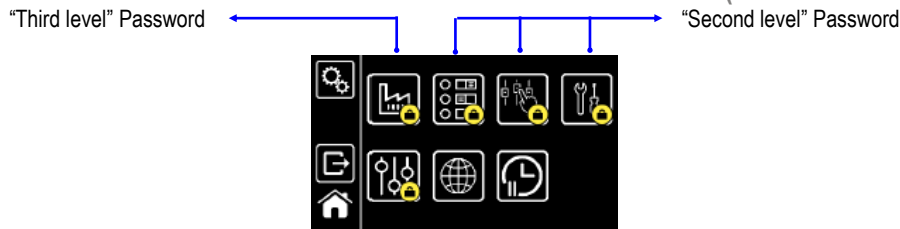

"OPERATOR" LOGIN (FIRST LEVEL)

The operator must know the first level Username and Password to Login. Operators have permission to change and save recipes.

To Login, follow the procedure below.

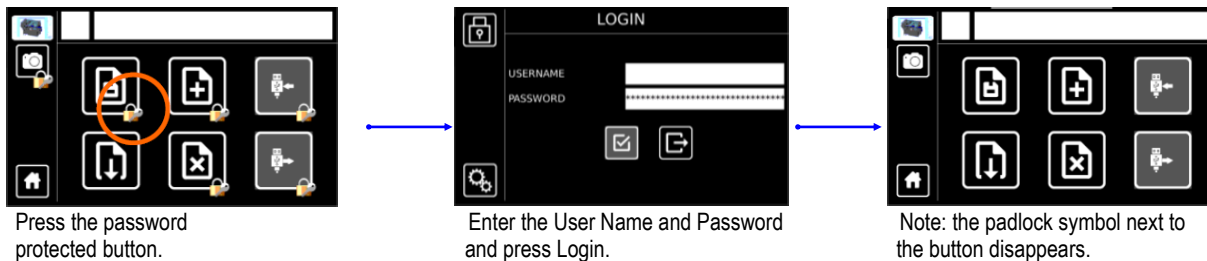

LOGOUT

To Logout and restore protections; follow the procedure described below.



RECIPE

The machine is supplied with 2 recipes saved with standard parameters (It can however store up to 100 recipes).

LOADING A RECIPE

To load a recipe, Follow the procedure below:

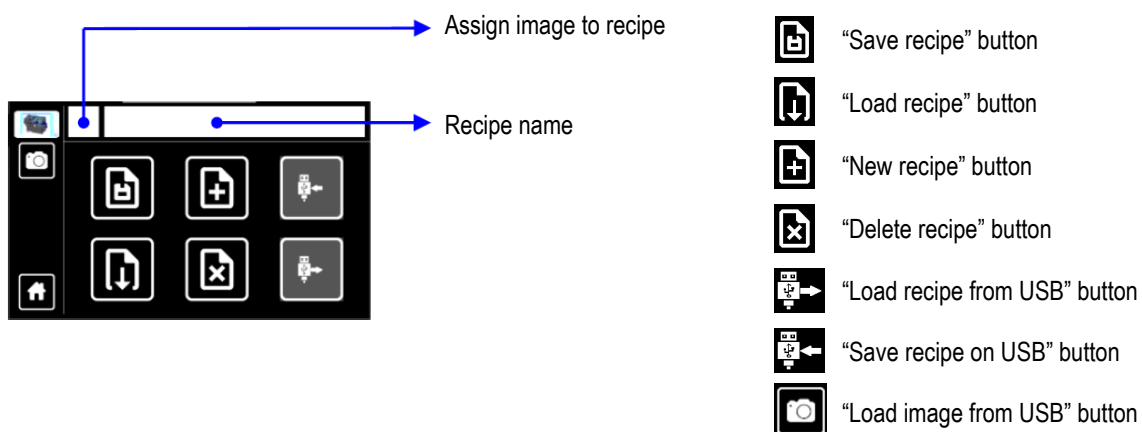
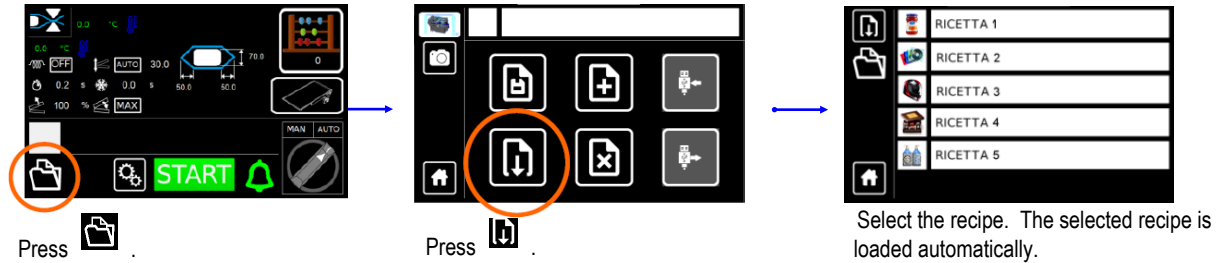

NEW RECIPE CREATION



Press .



Enter the name of the new recipe.
Press .

The new recipe has copied the settings of the recipe loaded in the machine.

DELETING A RECIPE



Press .

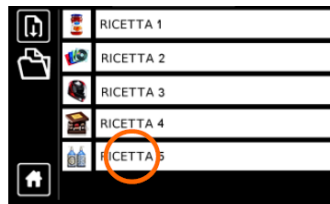

Select the recipe to be deleted.



Press YES.

SAVING DATA



Press to save the changes made to the recipe.

RECIPE IMAGE

Loading image from USB pen drive

Insert the USB drive with the images in the outlet on the control panel.

The images (.png or .jpg files, max 100Kb, max 800x600 pixel) must be archived in the main root of the USB pen drive.



Press .



Press and select the image to be loaded.

Associating the image to the recipe



To associate an image to the selected recipe, tap the space next to the name.

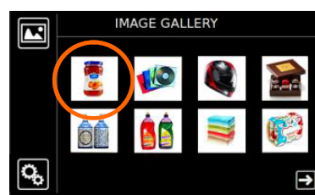

Select the desired image.



The image appears next to the name.

RECIPE MANAGEMENT

The recipes can be managed (Edit parameters/Create new programs) with a “Standard” or a “Fast” procedure.

STANDARD MANAGEMENT

“Standard” recipe management involves changing the parameters from the initial page by pressing the relevant area (e.g. sealing bars, film)

SEALING BAR PARAMETERS

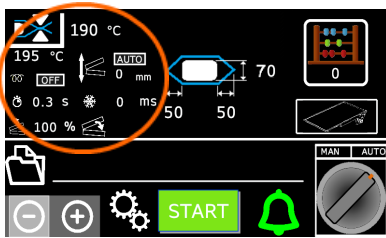



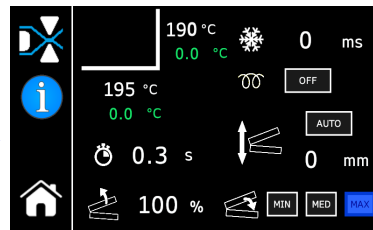



To edit the values, press anywhere on the screen and go to the settings page.



The parameters that can be adjusted are:

- Front and side sealing bar temperature
- Sealing time
- Sealing bar opening position
- Sealing cooling
- Pre-heating
- Sealing height
- Sealing bar closing pressure.

	<p style="text-align: center;">Front and side sealing bar temperature</p> <ul style="list-style-type: none"> → “Set” front sealing bar temperature → “Actual” front sealing bar temperature → “Set” side sealing bar temperature → “Actual” side sealing bar temperature <p>Press the number indicating the temperature to set and enter the value.</p> <p>Note: The initial page displays the “actual temperatures”. The colour of the thermometer indicates its status:</p> <ul style="list-style-type: none"> Red thermometer The machine is in the heating phase. The actual temperature is lower than the set temperature. Blue thermometer The machine is in the cooling phase. The actual temperature is higher than the set temperature. Green thermometer The machine is at the set temperature. The actual temperature matches the set temperature.
	<p style="text-align: center;">Sealing time</p> <p>Press the number indicating the sealing temperature and set the value.</p>

	<p style="text-align: center;">Sealing bar opening position</p> <p>Adjust the percentage opening of the sealing bar.</p> <ul style="list-style-type: none"> □ Machine without "Belts approaching"  : (30 – 100) □ Machine with "Belts approaching"  : (60 – 100) (see paragraph "Infeed belt parameters") <p>Set minimum sealing bar opening in order to reduce the closing and opening time and thus increase the packaging speed.</p>
	<p style="text-align: center;">Sealing cooling (0-3 s)</p> <p>Press the number indicating the sealing cooling time and set the value (default: 0 s). The function is used for all plastic films, such as polyethylene, which require cooling time to consolidate the seal. The sealing bar opens, but film advancement is delayed by a set amount of time.</p>
	<p style="text-align: center;">Pre-heating</p> <p>ON: adjusts the time of the first seals to ensure the contrast bar heats correctly. Recommended for low and light products.</p> <p>OFF: Not set.</p>
	<p style="text-align: center;">Sealing height</p> <p>Adjusts the sealing position with respect to the belt. Values: AUTO / MAN. If set at AUTO sealing is performed at half the height of the product. Ideal for standard products. If set at MAN sealing is performed at the set measurement (measured starting from outfeed belt surface). Values: 10 – 100 mm / 0.4 – 3.94 in.</p>
	<p style="text-align: center;">Sealing bar closing pressure</p> <p>Regulates the pressure of the film sealing bar to optimise the cut. Values: MIN / MED / MAX</p>

FILM PARAMETERS (WITH MACHINE IN MANUAL MODE)



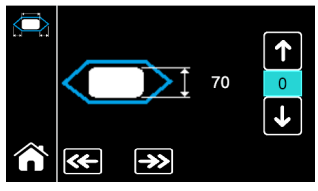

Press anywhere on the screen and go to the settings page.





Opening the inverter triangle

To set the opening of the inverter triangle, press the height (e.g. 70) and enter the desired value.

Another option for opening them is to move the upper inverter by pressing buttons  and .

The upper inverter will move according to the set measurement.

After finding the correct position, press the height (e.g. 70) and set it.

Buttons  and  are used to move the in-feed belt in both directions of travel.

FILM PARAMETERS (WITH MACHINE IN AUTOMATIC MODE)



Press anywhere on the screen and go to the settings page.

PACKAGING OF PRODUCTS WITH A REGULAR SHAPE

If packaging products with regular shape, we recommend the automatic setting (Do not mark the box with a flag, next to "Product Length").

In this case the film is sealed when the photocell reads the end of the product + the rear film length.

The available settings are: Feeding Start Delay, Product Height, Rear Film, Front Film

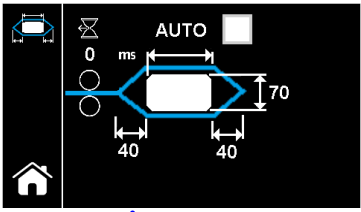

- **Feeding start delay:** adjusts film feeding start with respect to product arrival (default: 0 ms).
- **Product height:** adjust the position of the triangles.
- **Rear film:** adjust the amount of film you want to leave behind the product.
- **Front film:** adjust the amount of film you want to leave in front of the product.

PACKAGING OF PRODUCTS WITH AN IRREGULAR SHAPE

If packaging products with an irregular shape, We recommend the manual setting (Do not mark the box with a flag next to "Product Length").

In this case, the film is sealed when the photocell reads the start of the product and the set height (e.g. 180).

The available settings are: Product Length, Feeding Start Delay, Product Height, Front Film, Rear film (only with horizontal product sensor).

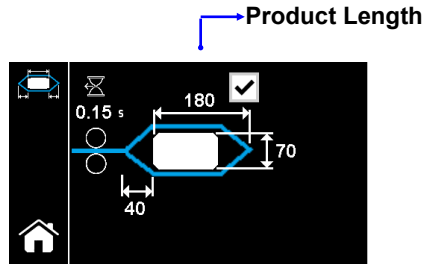

INFEEED BELT PARAMETERS

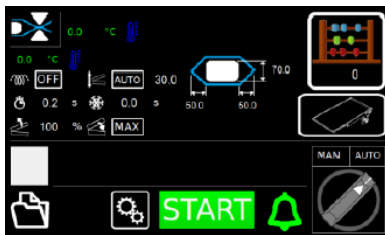

With the machine in press . Used to go to the first settings page.

On the first page it is possible to set:

- Photocell Filter,
- Belt Speed,
- Belt Mode: Continuous or with Pause,
- Loading Photocell Enabling (Optional),
- Horizontal or Vertical Photocell Selection

0.05 s Photocell filter: Adjusts the length of time for which the photocell must ignore a missing signal (advisable when processing irregular product formats). Values: 0 ÷ 1.

85 % Belt speed: adjusts the belt speed (20-100%)

Belt mode "continuous": belt always running

Belt mode "with pause": belt stopped during sealing to make it easier to form the package.

Loading photocell (OPTIONAL): to be used when you want the in-feed and outfeed belts to stop if no products to be packaged are loaded (if the photocell does not read the product for 10 seconds, it stops the belts). The function can be activated only if it is "included" among the OPTIONAL features. The machine comes as standard with two types of photocells to read the product: horizontal and vertical. Select the most suitable photocell for the product being packaged. With "standard" products, the photocell is selected according to the height:
 Horizontal photocell: suitable for product height > 200 mm / 7.9 in
 Vertical photocell: suitable for product height < 200 mm / 7.9 in

On the second page, it is possible to set:

- Film Loosening,
- Closing Conveyor
- Belt Reversal,
- Conveyor Belt,
- Printer

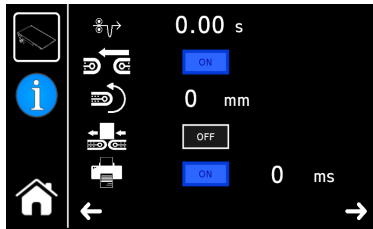

Film Loosening

Press the number indicating the film loosening time and set the value (default: 0.00 sec).



The function must be used when packaging high products (> 3.54 in / 90 mm) with not a lot of rear film.

At the end of film unwinding, before sealing, the outfeed belt moves backwards in order to loosen the film tension.

Closing Conveyor

When set on ON, the gap between the infeed and outfeed belts is reduced when conveying products into the seal area. Ideal for packaging small size products.



Values : ON / OFF.

Belt Reversal

Adjusts the distance between the products. After the belts have stopped running, the infeed belt (IN) runs backwards in order to move the product back by the programmed distance.



Values: 0 - 19.69 in / 0 - 500mm.

Conveyor Belt

It is the condition of use in which the machine works as a conveyor belt.



The belts convey the products from the infeed area to the outfeed area, without being film wrapped.

The sealing bar and opening film triangles fully open to allow the passage of products.

VALUES: ON / OFF.

Printer



The function is only available if  is included in the OPTIONAL FEATURES.



Printer on.



Printer off.

On the third page, it is possible to set:

- Load Belt,
- Unload Belt,

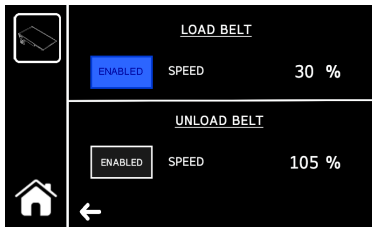

Load belt

The function is only available if is included in the OPTIONAL FEATURES.



Loading belt on.

Adjust the load belt speed with regard to the speed of the infeed belt (IN). Values: 20 ÷ 100.



Loading belt off.

Unload belt

The function is only available if is included in the OPTIONAL FEATURES.



Unloading belt on.

Adjust the unload belt speed with regard to the speed of the outfeed belt (OUT). Values: 100 - 130.



Unloading belt off.

FILM UNWINDER PARAMETERS

Press the button to enter the data related to the manual settings of the film unwinder, so that every time you load a program, you can apply the saved settings.

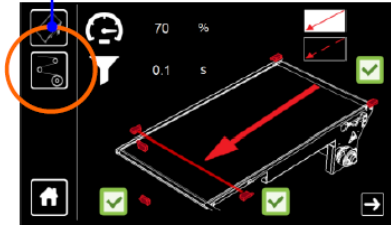

	1	Enter the film reel position with reference to the millimetre scale (X1) , Figure 4, Page 39.
	2	Enter the number of micro punches (MF) used.
	1	Enter the position of the return roller (R5) with reference to the scale (X2), Figure 1, Page 38.
	0.20 5	Used to create slack in the film on the rewinder rollers, delaying the moment when the rewinder stops.
		0.2 for product height < 100 mm / 3.9 in
		0.4 for product height > 100 mm / 3.9 in

Film Register



The function is only available if **PRESENT** is included in the OPTIONAL FEATURES.



"Film Register" on.

The function enables reading out the marks on opaque or coloured film by a specific photocell (OPTIONAL FEATURE).



"Film Register" off.

Film punch



The function is only available if **PRESENT** is included in the OPTIONAL FEATURES.



"Film punch" on.



"Film punch" off.

STANDARD MANAGEMENT (FROM "IMAGE")

Another way of managing the parameters of a recipe is using button  .

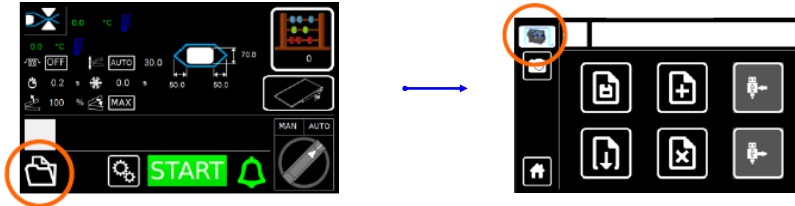

Press  .

Press  .

This displays the image of the machine and, if selected, of the tunnel as well.

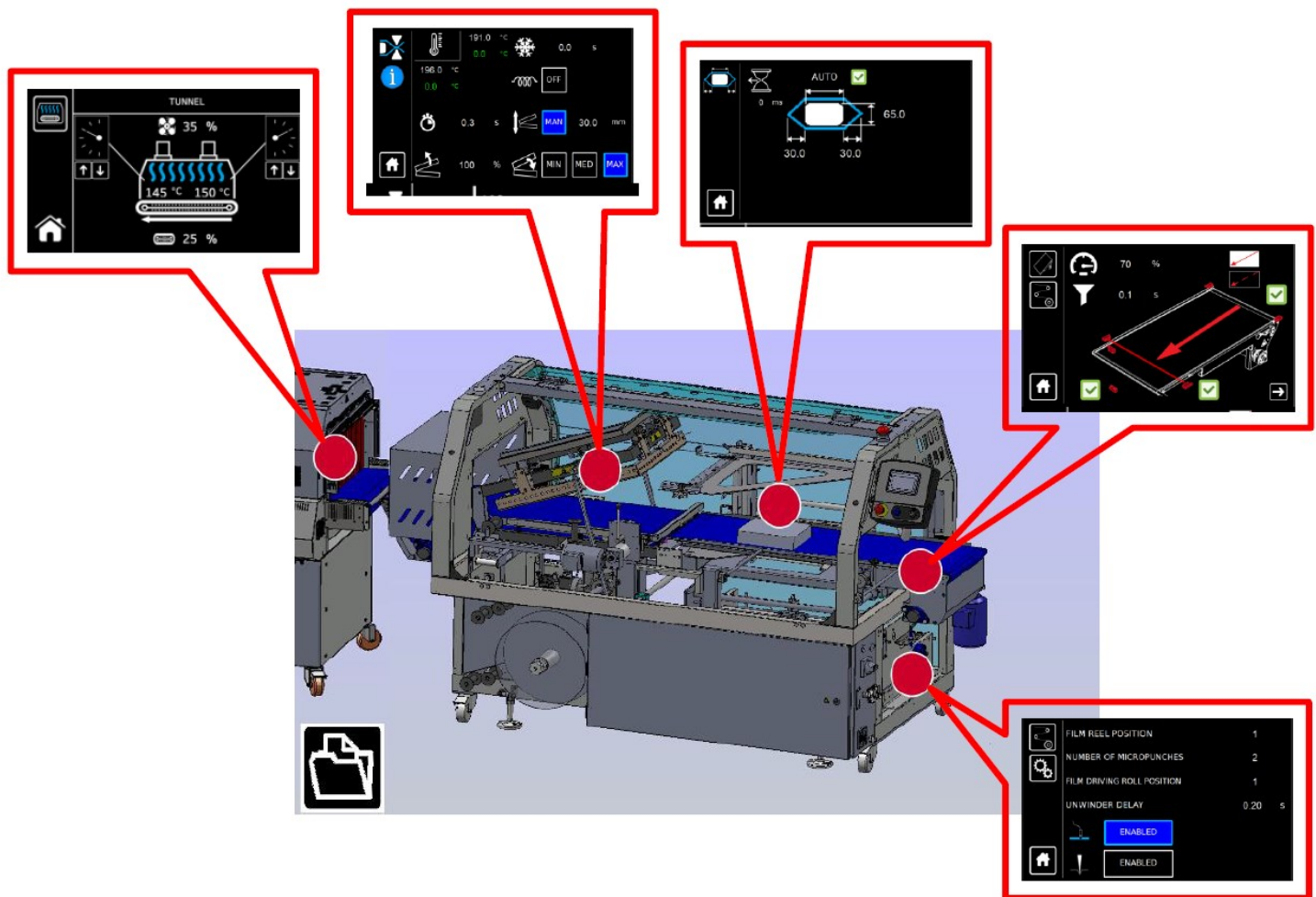

Press the "red Dot" to display the screen with the parameters that can be set in the area involved.



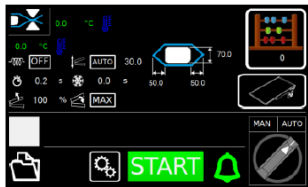

BATCH COUNTER

This function sets the number of products to be packaged.

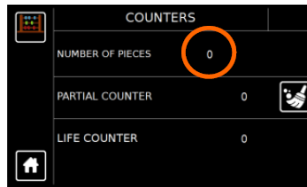

With the machine in  press .



Enter the number of products to pack (batch).
If set to "0", batch production is disabled.
Press .

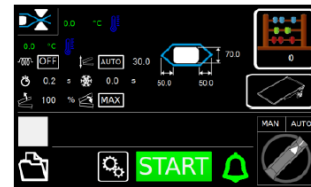

Press **START**.
With the batch function active, the number under the symbol  indicates how many products have been packaged since the production batch started.

Once the set number of products have been packaged, A025: BATCHED NUMBER REACHED, alarm will activate.

CONFIGURATION PAGE

This configurations page can be accessed from the home page by pressing .

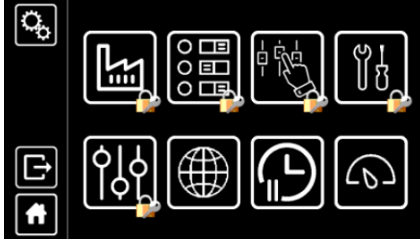

“Factory parameters” button



“Optional” button



“Manual controls” button



“Service” button



“Configuration” button



“Power meter” button. Only available with power meter option installed.



“Language settings” button



“Pause time” button



“Logout password” button

PAUSE TIME

This function is used to program the machine's "Pause" Time.

During this phase, the sealing bar resistor switch off (A condition that ensures considerable energy savings), while all of the other machine function stay on.

Once the pause time elapses, the resistors are heated up again.

This function is very useful for workers who and when they finish any kind of work break and start their shift again. Then need to have the machine at the right temperature. Ready for usage or for maintenance procedures requiring adjustments with the seal bars off.

Follow the procedure below to set the pause time.



Press  to go to the settings pages.

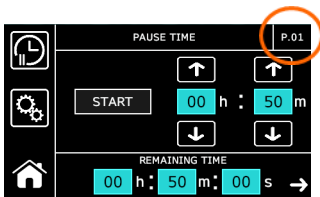

The first page is used to set the hours and minutes when the machine operation will be paused.

Press  to start the countdown, at the end of which the resistors resume operation.

Press  and the home page will display a pop-up window indicating the remaining time till the end of the pause.

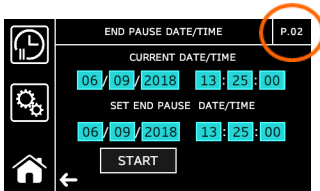

The second page is used to set the date and time to end the pause time.

Press  to pause the machine up to the set date and time.

Press  and the home page will display a pop-up window indicating the date and time when the pause will end.

FILM FEATURES

This machine can work with polyolefin heat-shrink film between 9 and 38 micron, 40-150 gauge, thick, both technical and suitable for food.

The special features of our films assure their outstanding reliability, with regard both to compliance with laws in force and an excellent machine performance.



Consult the data and safety sheets of the films in use and observe the corresponding instructions!

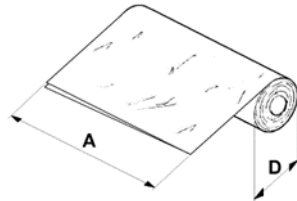

A = 27.5"

D = 11.81"

BAND A CALCULATION

Band A = b + c + 3.94 in

By Band "A" We mean the width that the film must have to package the product

Note: it may be necessary to increase the amount of film friction (3.94in) indicated in the formula, for high products or with complex shape.

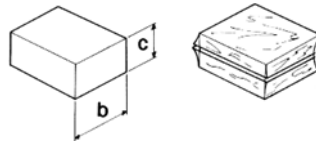

MAX PACKAGE SIZE

a = 23.62 in

b = 15.75 in

c = 9.45 in

Note: Measurements show refer to the maximum for the single dimension.

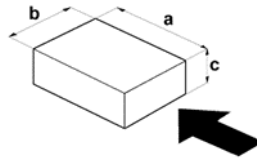

ITEMS WHICH MAY BE PACKAGED

These machines are capable of packaging a wide range of different products. They are used successfully in the following sectors: food, marketing, graphics and mailing, large distribution, industry, fabrics

ITEMS WHICH MAY NOT BE PACKAGED

The products listed below must absolutely not be wrapped to avoid permanent damage to the machine and serious injuries to the operator:

	<ul style="list-style-type: none"> • Wet and unstable products • Liquids of any kind and density in fragile containers • Flammable and explosive materials • Pressurized gas cylinder of any kind • Loose and volatile powders • Any materials and products not listed but which might harm operator and damage the machine.
---	--

LOADING AND ROUTING FILM

To insert the film, Set the Machine to "MANUAL" Mode.

Turn the "SAFETY DEVICE EXCLUSION" Switch (S3) to ON and Open the guards (C1), (C2), (C3).

STEP 1

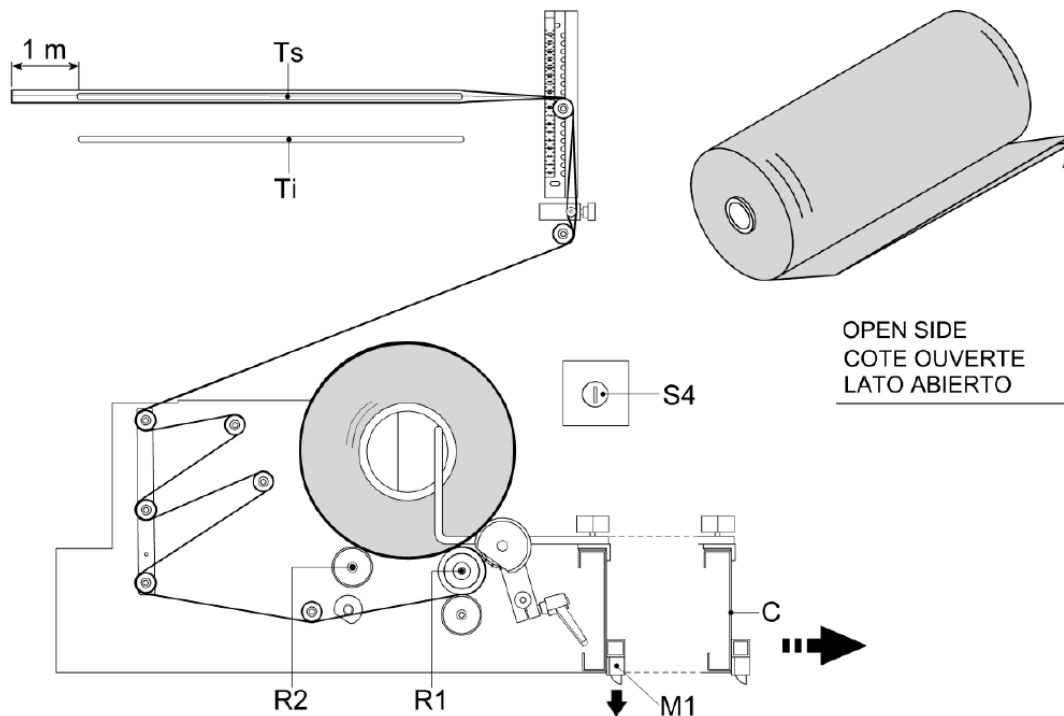

To make it easier to position the film reel, take out the carriage (C) supporting the reel (which means lowering handle M1 and pulling the carriage).

Position the film reel on rollers (R1) and (R2).

The open side of the film must always be as indicated by the arrow.

(Note: the unwinding direction of the reel must be specified when ordering the film).

Insert the film as shown in the figure.

To make it easier to insert the film, press button (S4) to the right of the reel.

Press the button to activate the motorised roller that the reel is resting on, thereby providing the required amount of film.

Insert the two ends of the film, one on top and one under the upper guide triangle (Ts).

Take the two ends of the film and unwind about 1m, 3ft.

FILM SETUP & ADJUSTMENTS



STEP 2

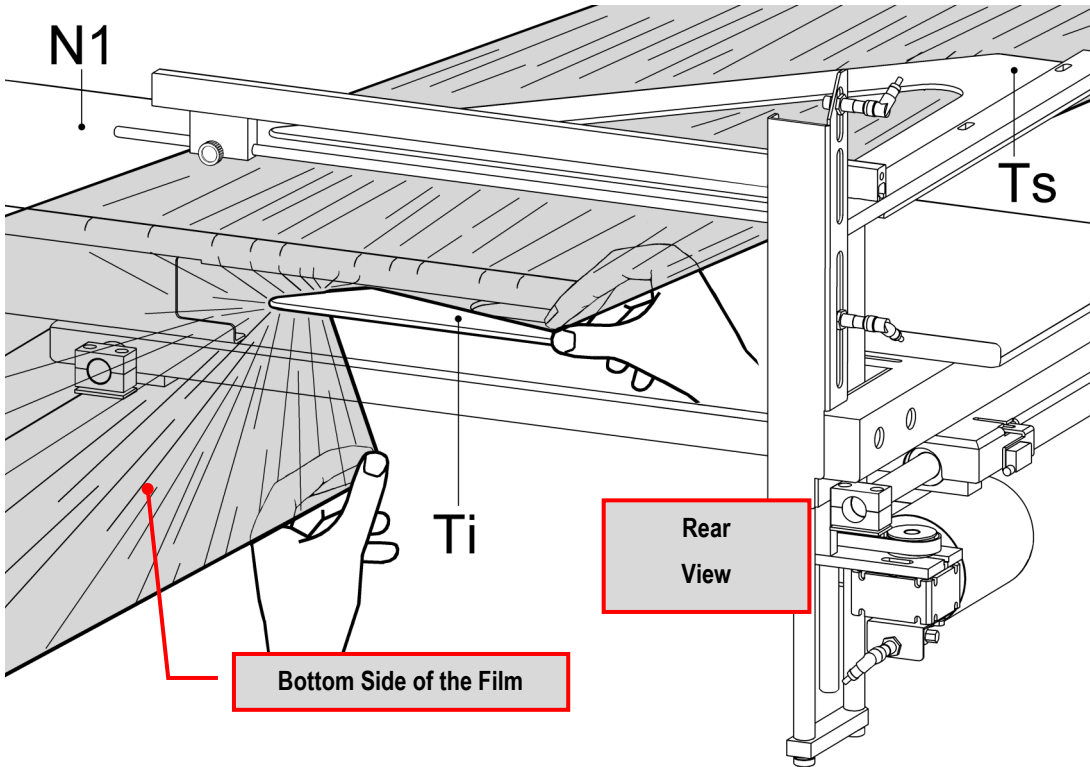

Take the lower end of the film near the rear of the reversal triangle and pass it under the lower triangle (Ti) from the outside inwards and over the infeed belt (N1).

STEP 3

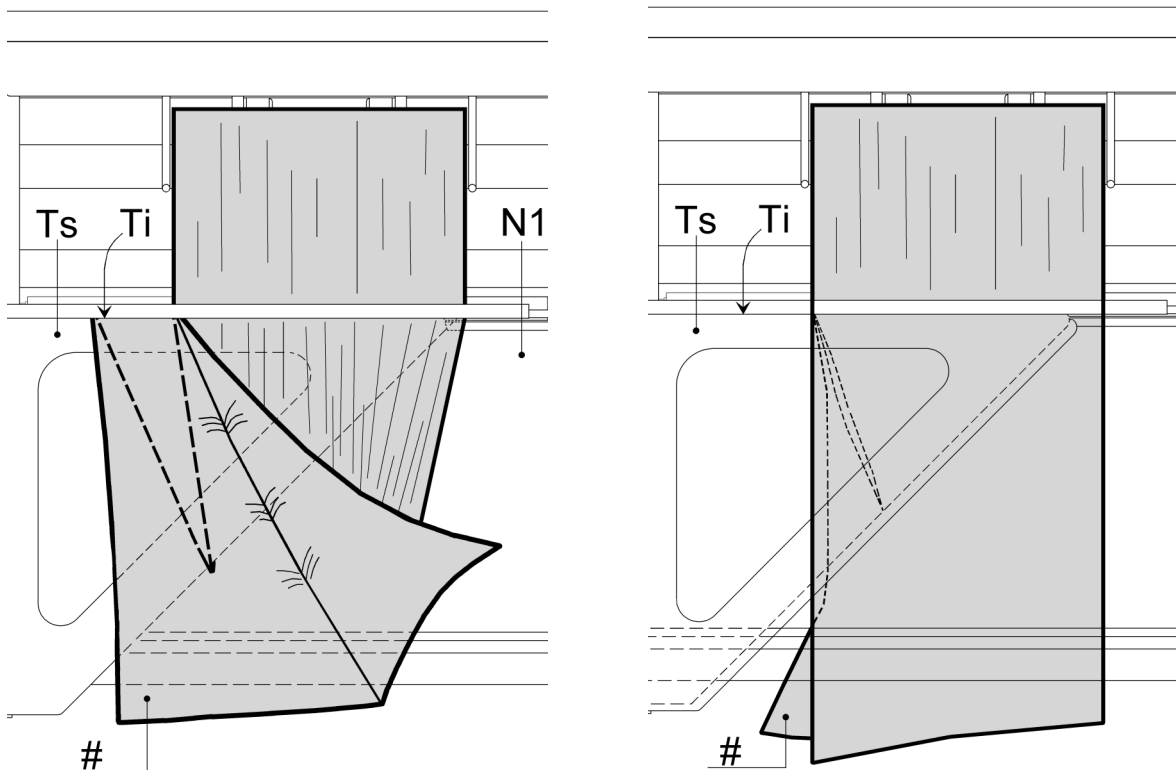

Then pass the upper side of the film over the upper triangle (Ts).

FILM SETUP & ADJUSTMENTS



STEP 4

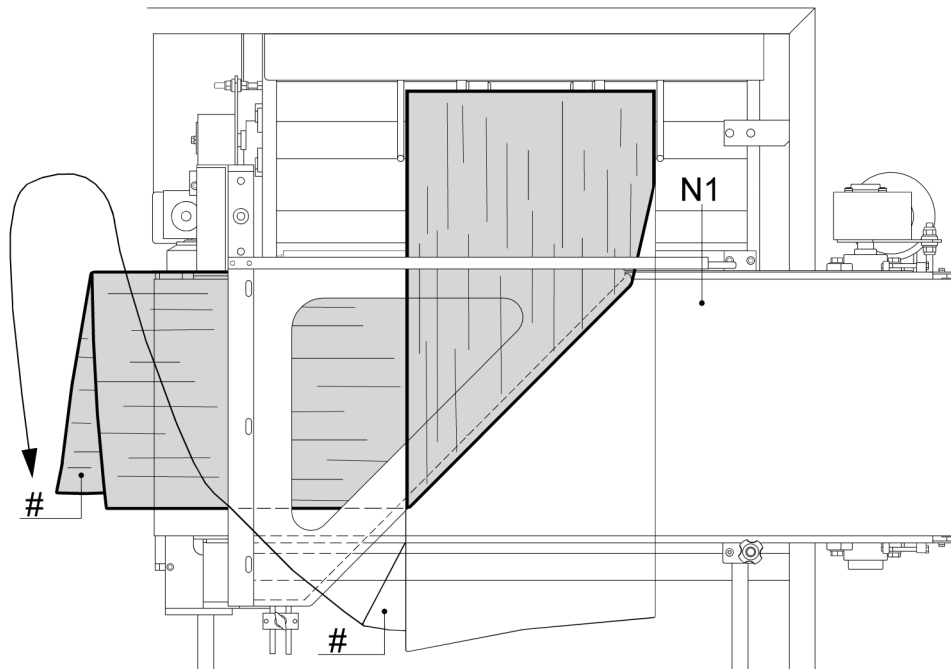

Move the end of the film (#) that will go inside the triangles to the left, parallel with the infeed belt (N1) and pass the film under and above the infeed belt, aligning the ends of the film right after the belt itself.

STEP 5

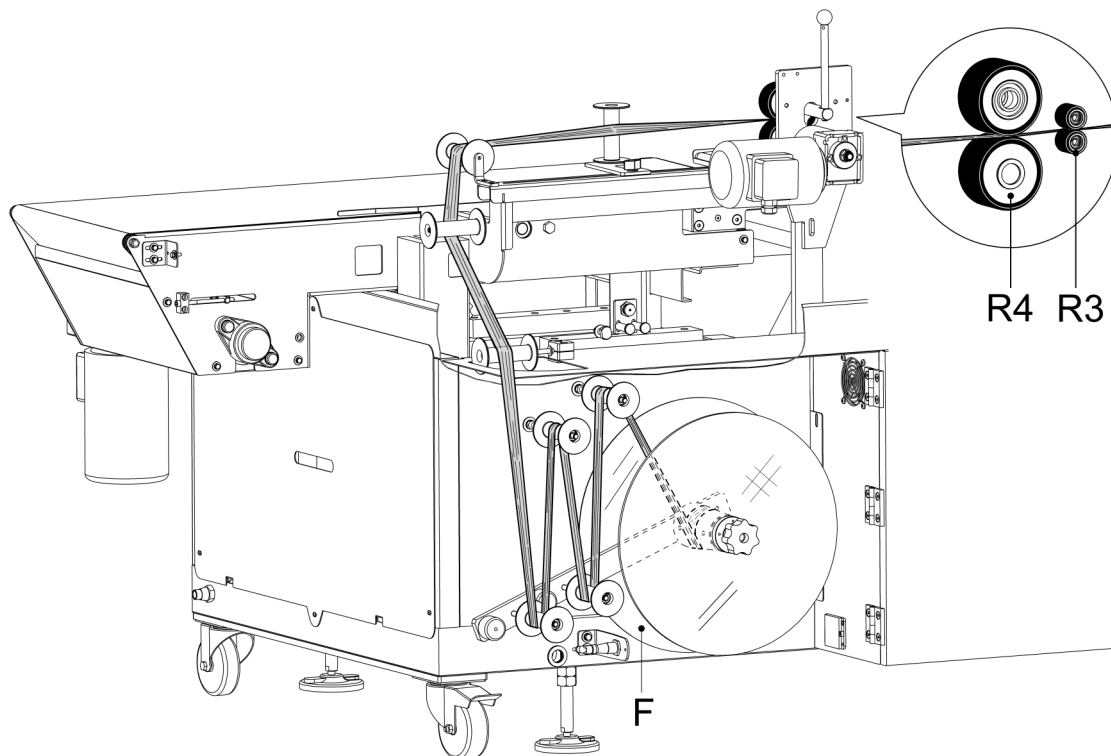

Pass the film between the two rollers (R3) and between the two wheels (R4) of the pulling device.

At this point perform a number of sealing cycles by pressing the  button, so as to create a length of film that is long enough to complete insertion as shown in the diagram.

In order to seal the film you must close the front (C1), (C2), (C3) guards.

Lastly, tie the film onto the pin attached to the rear flange (F).

ADJUSTMENTS

Before packaging, it is necessary to make a few "Manual" Adjustments.

FILM REEL POSITIONING

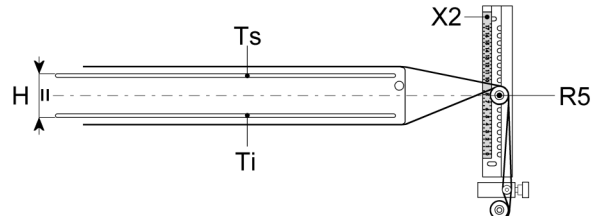

The film reel must be positioned according to opening "H" of the triangle.

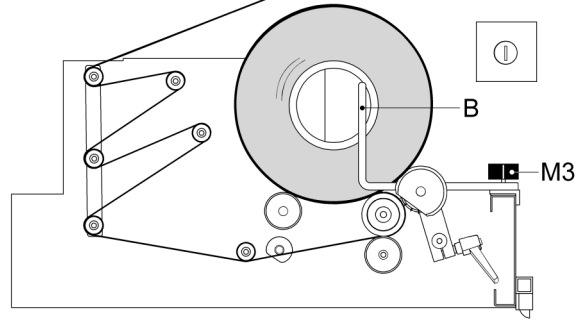

Figure 1

Reel positioning is correct when the right side of the reel is at distance "A" equal to half the distance of opening "H".

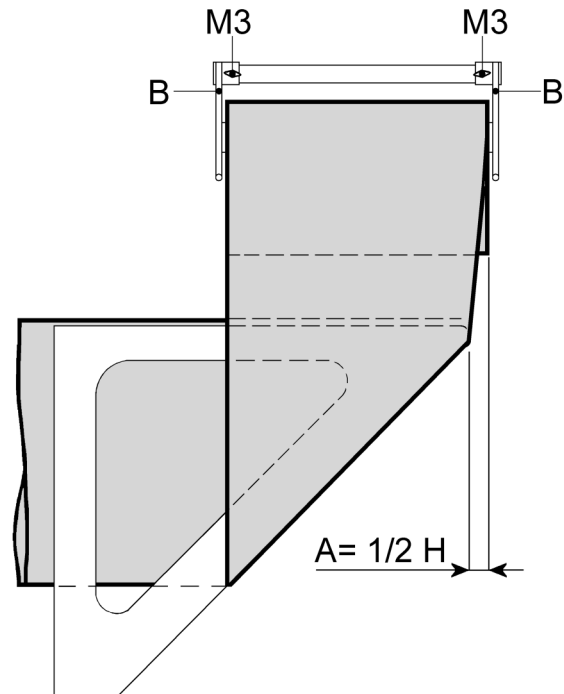

Figure 2

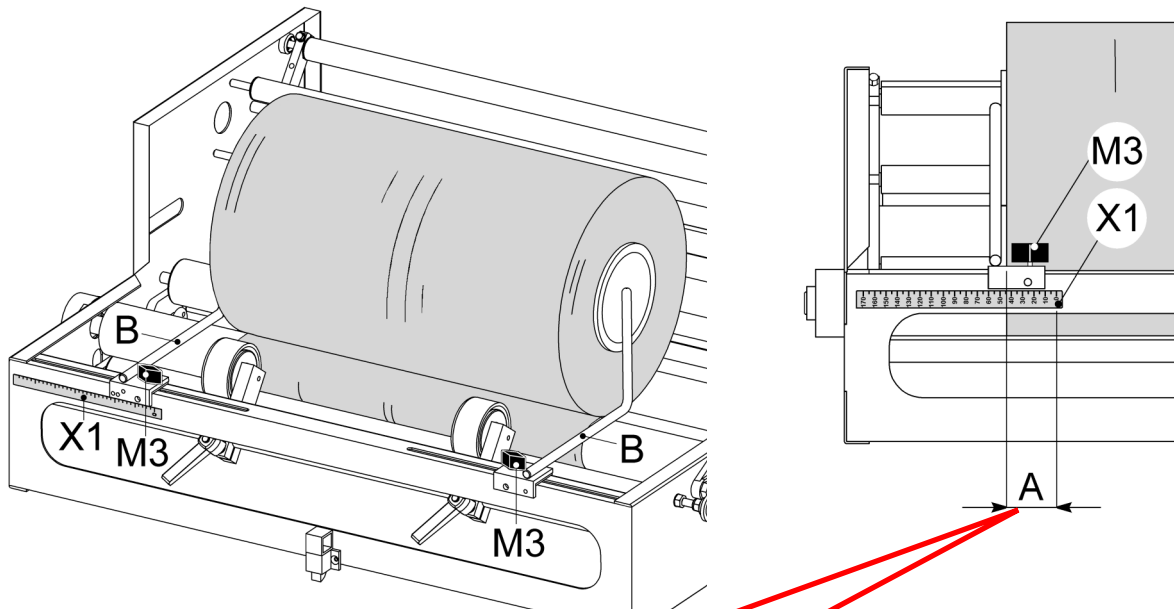
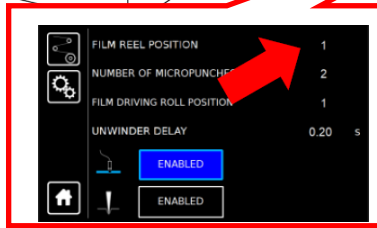

Figure 3

Figure 4



Then place the reel with reference to the millimetre ruler (HDX 2000) on the support.

Adjust the 2 Containment guides (B) by using the knobs (M3) in order to block the reel, leaving 0.2 in (5 mm) of space between the guides and the reel

POSITIONING THE MICROPUNCHES

Place the number of micropunches (MF) according to the dimensions and shape of the product in order to obtain the best packaging result.

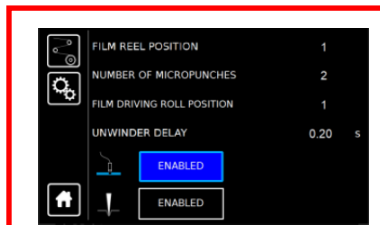
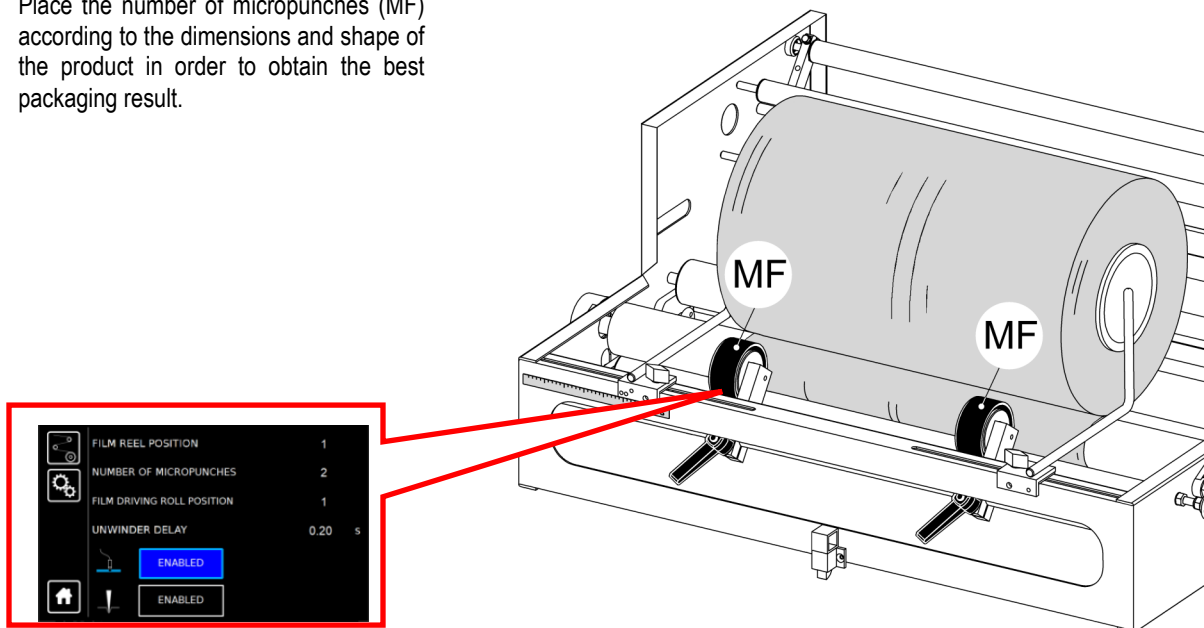

ADJUSTMENT OF “FILM SEPARATING” ROD AND RETURN ROLLER

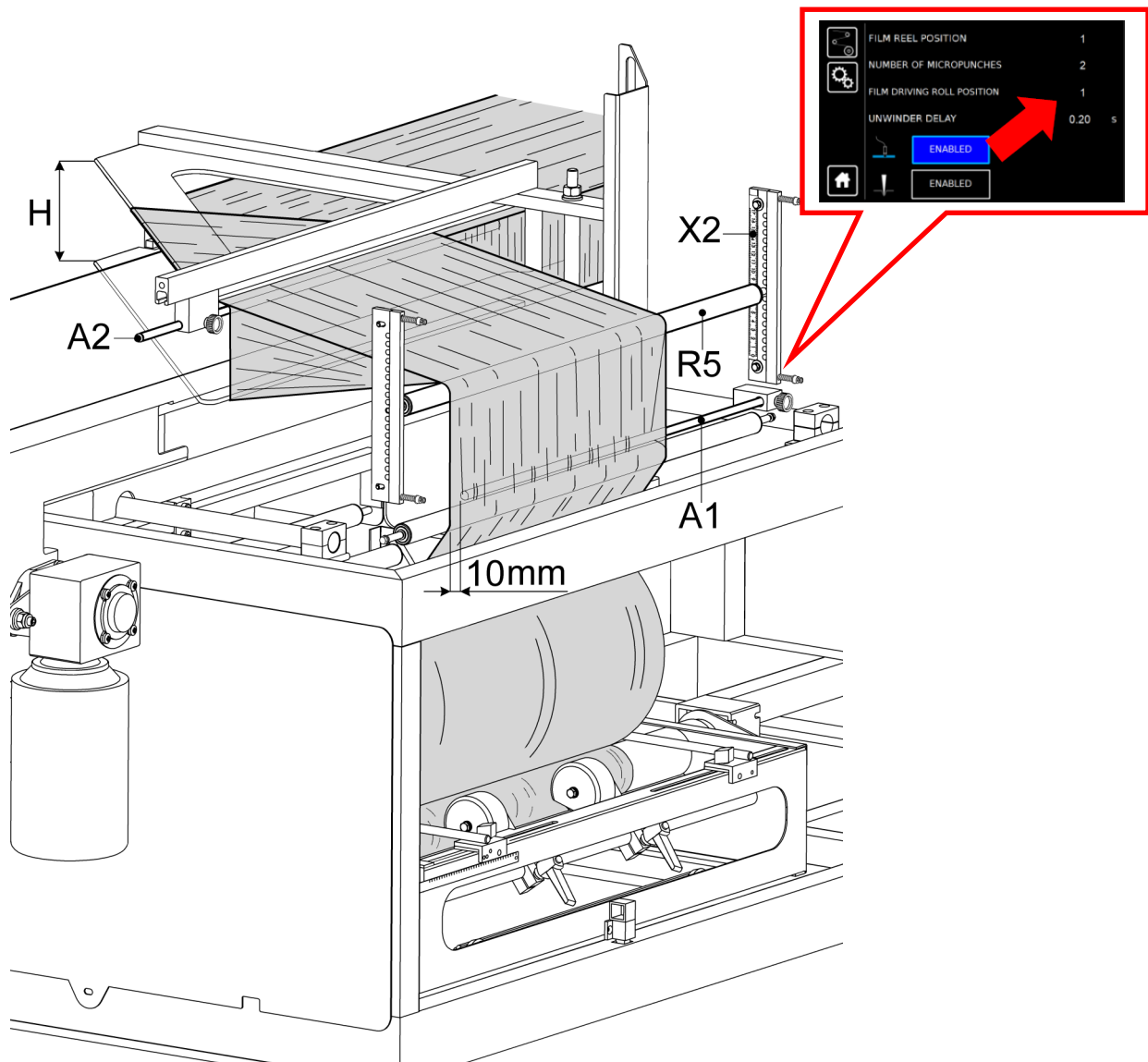

- The rod (A1) allows the 2 edges of the film reel to be separated.
Position the rod inside the two edges so the end is 0.39 in (10 mm) behind the crease of the film.
- Position the return roller (R5) according to the “H” opening of the triangles.
Refer to the millimetre ruler (X2) and position the roller at a measurement corresponding to half the opening of the triangles.

ADJUSTMENT OF “FILM LIFTING” RODS

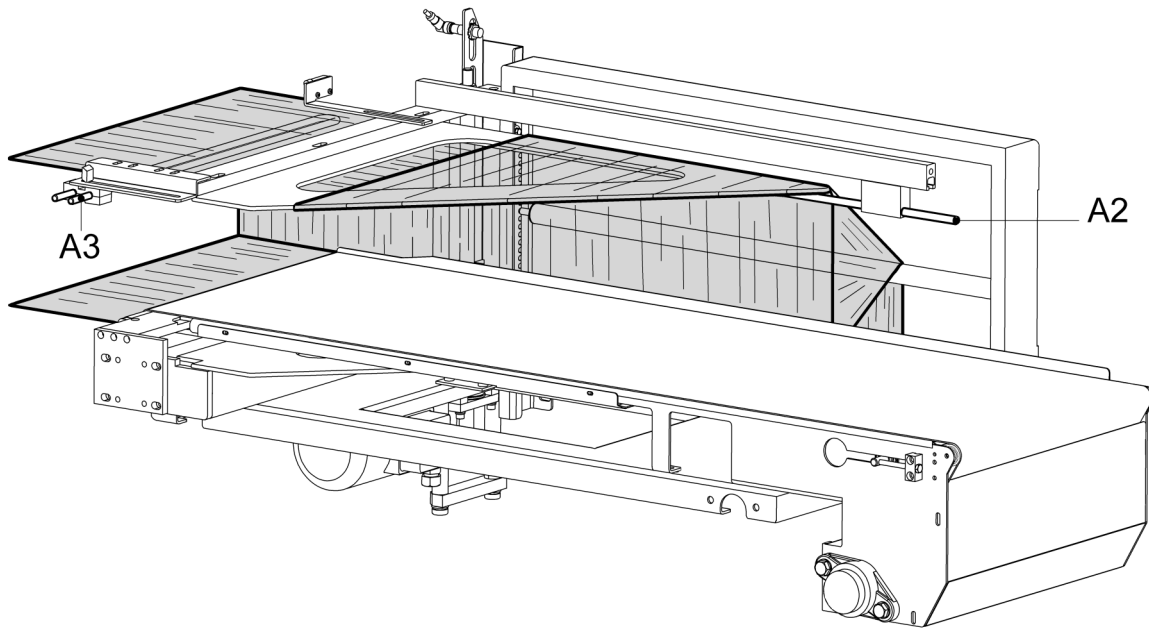

- Rods (A1) and (A3) are used to keep the film lifted correctly during product insertion. Adjust their position according to the dimension and shape of the product being packaged until the best packaging result is obtained.

INFEED BELT ADJUSTMENT

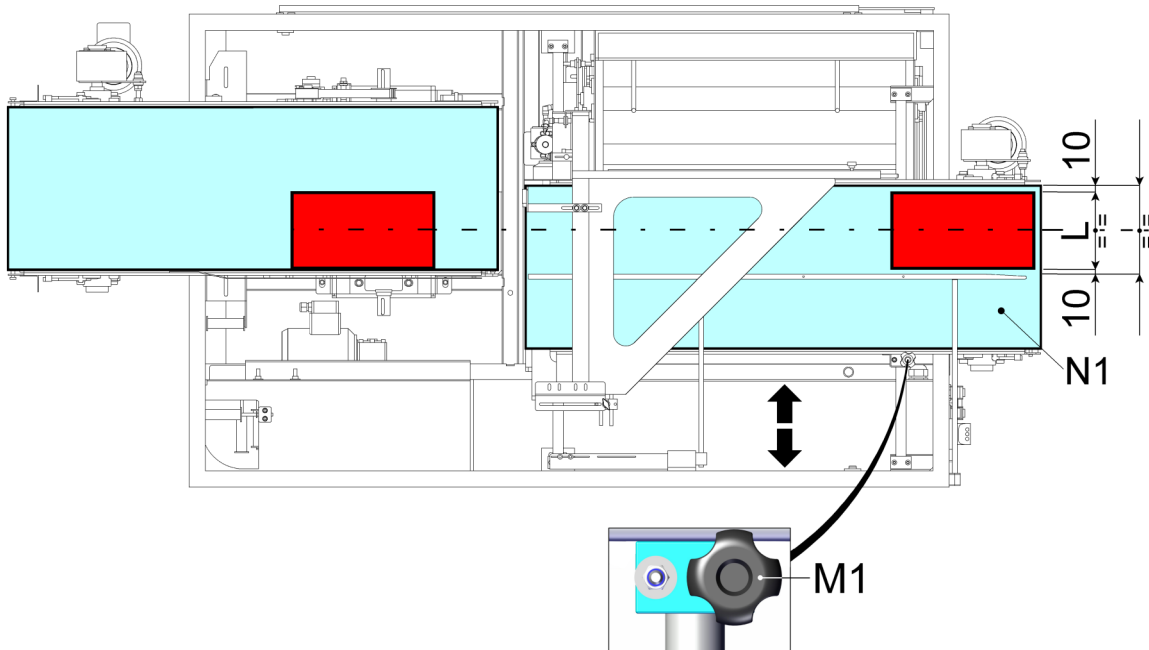

Adjust the position of the infeed belt (N1) according to the width (W) of the product being packaged, as shown below:

- Loosen the handle (M1) and adjust the position of the infeed belt (N1) so that the product has minimum clearance between the guide rod approximately 0.39 in (10 mm) and the rear shoulder of the belt approximately 0.39 in (10 mm).

BELT TENSION ADJUSTMENT

With the first package, and at least once a month. Check the Infeed and Outfeed Belts are aligned in the middle when moving. Should disbandment be noted, or noises heard, it could mean the roller where the belt slides are not at perfect right angles with the drive direction.

To Reset centring, It is required to adjust the belts tension by means of the screws located on the side.

To adjust tension:

- Loosen the locking nut (C);
- Tighten or loosen screw (A) or (B) according to the type of adjustment to execute,
- Lock the nut.

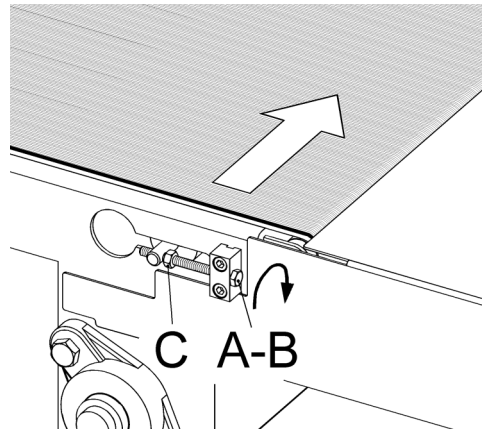

INFEEED BELT

Turn screw (A) clockwise in order to shift the infeed belt in the direction shown in figure ↑.

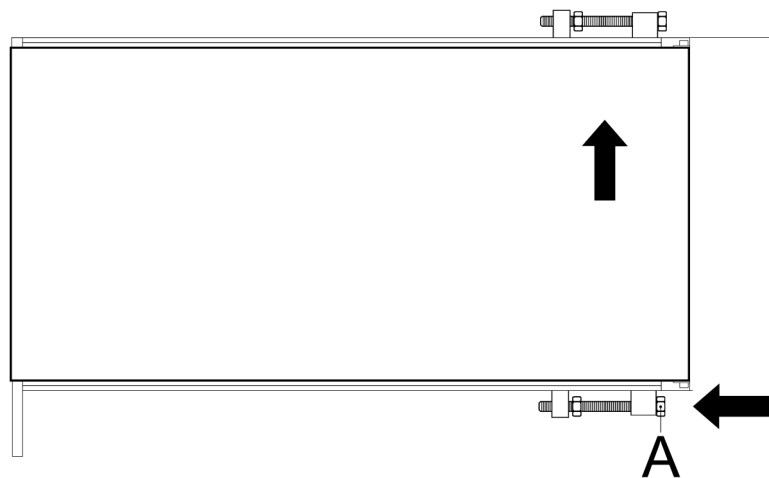

Turn screw (B) clockwise in order to shift the infeed belt in the direction shown in figure ↓.

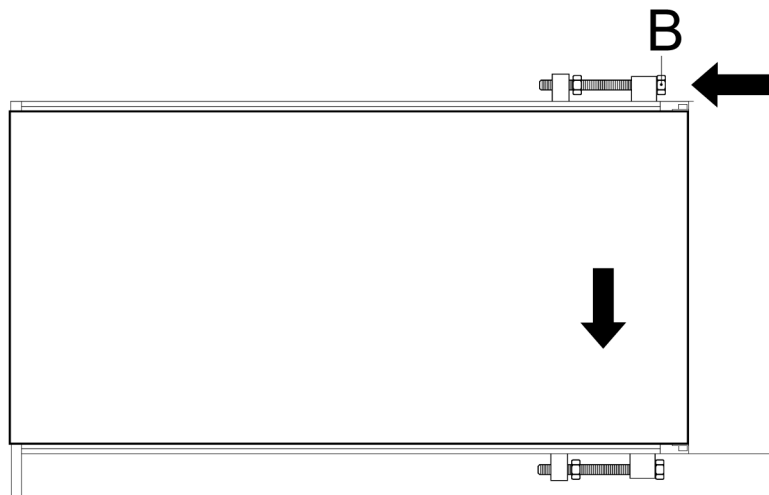

FILM SETUP & ADJUSTMENTS



OUTFEED BELT

Turn screw (A) counter-clockwise in order to shift the outfeed belt in the direction shown in figure ↑.

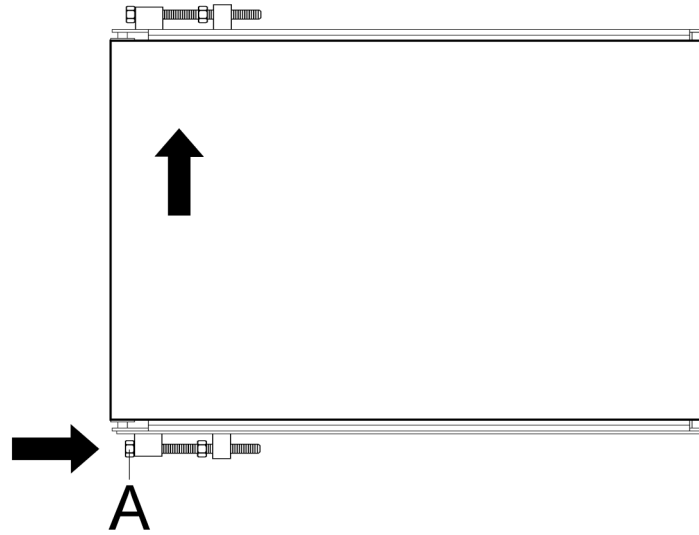

Turn screw (B) counter-clockwise in order to shift the outfeed belt in the direction shown in figure ↓.

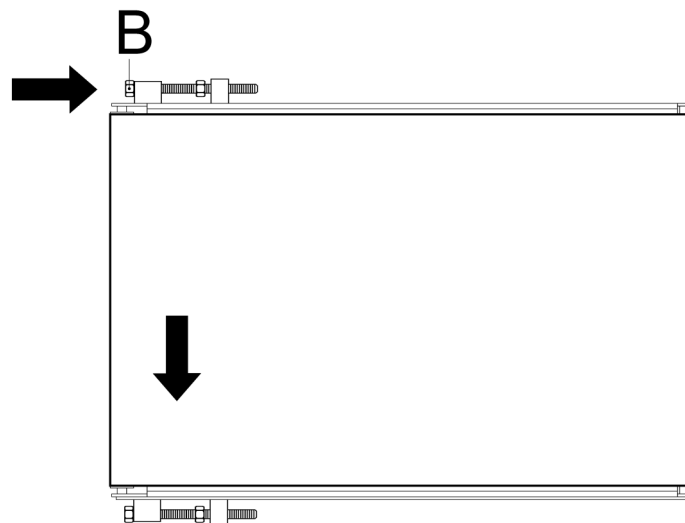

Correct belt tension is obtained when there is approximately 1.6 in (40mm) between the loading surface and the said belt when lifting it.

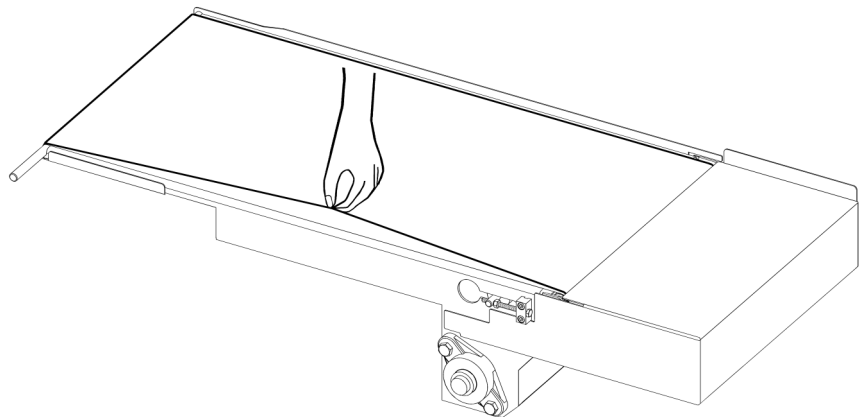

PACKAGING

Having made all the necessary adjustments, the machine is ready to proceed with packaging.

With the machine in "AUTOMATIC" mode, press the start cycle button **START**.

The belts will start operating and it is possible to place the product on the infeed belt (N1).

When the product passes along the outfeed belt, the sealing frame lowers in order to seal the film.

The packaged product moves towards the roller conveyor or inside the tunnel to shrink the film.

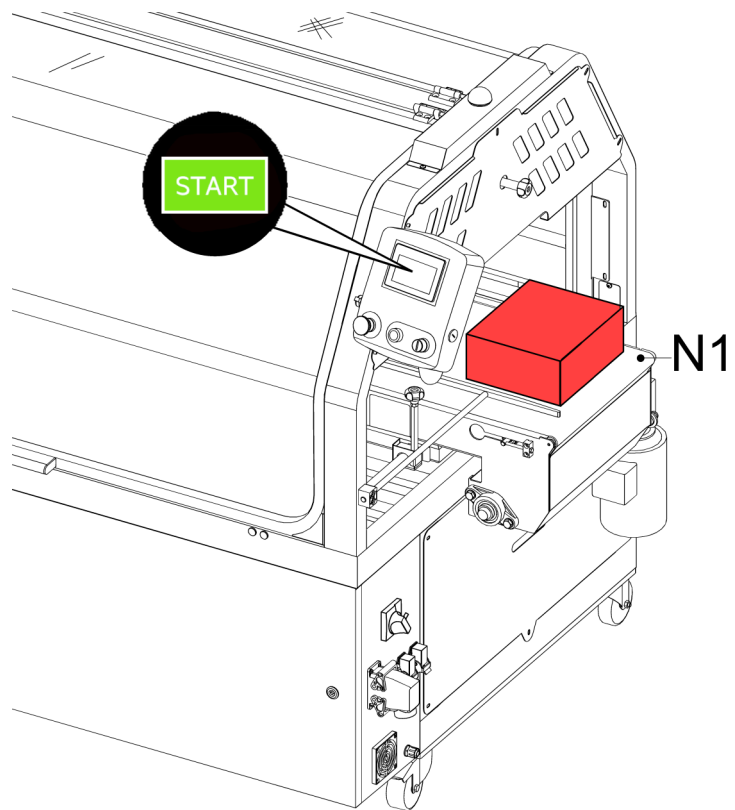

ALARMS

This machine provides a series of ALARMS needed to monitor any dangerous situations and malfunctioning. Each time an ALARM occurs, the Machine Stops.

The buzzer (P2) turns red and emits an acoustic signal. The  symbol appears on the display.

The alarm reset procedure is as follows

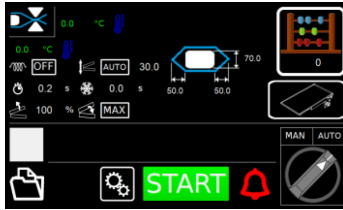

Press .



The display shows which alarm has been triggered.

Press  followed by .

Note: press  to stop the acoustic signal

	The machine is equipped with 3 “EMERGENCY” buttons, (S1.1), (S1.2), (S1.3). Press them together to block the machine instantly, stopping the work cycle.
---	--

The procedure for restoring this alarm is the following:

- Remove the cause of the alarm.
- Release the “EMERGENCY” Button by turning it to the right.
- Press RESET (S2).

PLC DIAGNOSIS

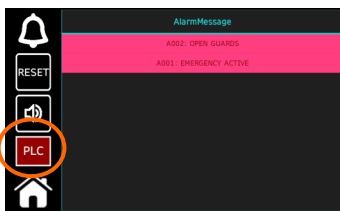

The  button displays the software version.

LIST OF ALARMS

NO.	ALARM	CAUSE	SOLUTION
A001	EMERGENCY ACTIVE	1 of the 3 "EMERGENCY" buttons (S1.1), (S1.2), (S1.3) has been pressed.	Remove the cause of the alarm. Release the "EMERGENCY" button by turning it to the right. Press the RESET button (S2).
		Only with "loading/unloading belt" optional feature The outlet plug for the belt connection has been removed, but the belt power cable is not connected correctly	Check whether the belt power cable has been inserted correctly into both the machine outlet and the belt outlet. <ul style="list-style-type: none"> Press the RESET button (S2) Press RESET on the display on the alarm page.
A002	OPEN GUARDS	1 of the 3 guards (C1), (C2), (C3) has been opened	Close the guard and press "RESET" (S2).
A003	BYPASS SAFETY GUARDS	The SAFETY OVERRIDE switch is on	Turn switch off
A006	MAXIMUM TRIANGLE HEIGHT	Sensor malfunctioning (B32)	<ul style="list-style-type: none"> Make sure sensor B32 is in correct position Check contactor QM5 is functioning correctly Place machine in MANUAL mode and lower triangle
A010	MACHINE HEATING	The elements in the machine are heating	Wait for elements to reach set temperatures
		The thermocouples (BT1, BT2) are faulty	Check electrical connections. Replace if faulty
		The solid state relay , (QS1, QS2), are not working	Check relays in electrical cabinet. Replace if faulty
A011	REWINDER FULL	The film scrap collection Rewinder is full	<ul style="list-style-type: none"> Remove the film from the rewinder Press RESET on the display on the alarm page.
		"Full Rewinder" photocell (B10) malfunction	<ul style="list-style-type: none"> Check the photocell electrical connection and that it is properly fixed to its support Check that the photocell does not read any film scrap between the photocell and the reflector Press RESET on the display on the alarm page.
A012	UNWINDER: ROLL FINISHING	The film reel is almost finished. It is only a warning: the machine will not stop but continue running	<ul style="list-style-type: none"> Wait for the reel to finish and replace it Press RESET on the display on the alarm page.
	with optional "reel end warning photocell kit"	"End of reel" photocell (B53) malfunction	<ul style="list-style-type: none"> Check the photocell electrical connection and that it is properly fixed to its support Press RESET on the display on the alarm page.
A013	UNWINDER: FILM FINISHED	The film reel has finished	<ul style="list-style-type: none"> Replace the reel Press RESET on the display on the alarm page.
	with optional "Film end photocell kit"	"End of film" photocell (B54) malfunction	<ul style="list-style-type: none"> Check the photocell electrical connection and that it is properly fixed to its support Press RESET on the display on the alarm page.
A014	BELTS NOT SPACED	Motor malfunction (M8)	<ul style="list-style-type: none"> Check operation and electrical connections Press RESET on the alarm display page
		Sensor malfunction, (B3) and/or (B12)	<ul style="list-style-type: none"> Check sensor connections and mounting Press RESET on the alarm display page

ALARMS & TROUBLESHOOTING



NO.	ALARM	CAUSE	SOLUTION
A015	TEMPERATURE CIRCUIT ERROR	The thermocouples (BT1) and (BT2) are not working	Check the electrical connections and replace if faulty
A017	UNWINDER: TIME OUT	The film unwinder has turned for too long due to mechanical block of the lever (L)	Clear blockage preventing lever from moving freely
		Unwind start sensor, (B8), malfunction	<ul style="list-style-type: none"> Check electrical and mechanical connections. Press RESET on the alarm display screen.
A020	INVERTER: INVERTER ERROR	Inverter is in error	<ul style="list-style-type: none"> Check code of error on inverter display Press E-stop Wait 10 seconds and then release E-stop Press the RESET button, (S2)
A022	MAINTENANCE IN PROGRESS	The Operator is controlling the machine manually	Once manual control is complete, press the RESET button on the alarm screen
A023	EMPTY LOAD BELT (with optional loading belt product sensor)	The product sensor (B51) is waiting to see a product.	The alarm will clear when a product is detected
		Product sensor, (B51), malfunction	<ul style="list-style-type: none"> Check electrical and mechanical connections. Press RESET on the alarm display screen.
A025	BATCH NUMBER REACHED	The machine has packaged the set number of products	Press RESET on the alarm screen
A026	REWINDER: FILM BREAK	Film break	<ul style="list-style-type: none"> Fix the film Press RESET on the display on the alarm page. <p>Note: Make sure the film on the triangles is not excessively stretched out. If so, this means that the film unwinder is not working.</p>
A027	PHOTOCELL TIMEOUT	A product longer than the lateral sealing bar is being packaged	Package a product shorter than the lateral sealing bar.
A029	BELT APPROACHING: INVERTER ERROR	The inverter , (TS3), is in error	<ul style="list-style-type: none"> Check code of error on inverter display Press E-stop Wait 10 seconds and then release E-stop Press the RESET button, (S2)
A033	CENTER SEALING: TOP LIMIT SWITCH	Sensor, (B40), malfunction	<ul style="list-style-type: none"> Make sure sensor is in correct position Check that contactor (QM7) is working correctly In the MANUAL CONTROLS menu scroll to the CENTER SEALING control and press the down arrow to lower the seal jaw Press RESET on the alarm screen
A034	UNWINDER OUT POSITION	Sensor, (B35), malfunction	<ul style="list-style-type: none"> Check electrical and mechanical connections. Press RESET on the alarm display screen.
A035	TRIANGLE: MOVEMENT ERROR	Sensor, (B2), malfunction	<ul style="list-style-type: none"> Check electrical and mechanical connections. Press RESET on the alarm display screen.
A041	HOMING: TIMEOUT	The sealing bar homing does not end within the set time	Contact the technical assistance service.
A042	HOMING: FAILED PROCEDURE	The machine receives the sealing bar homing command, but is not ready	Contact the technical assistance service.
A046	CENTER SEALING: MOVEMENT ERROR	Sensor, (B42), malfunction	<ul style="list-style-type: none"> Check electrical and mechanical connections. Press RESET on the alarm display screen.
A048	PRINTER ERROR	Printer malfunction	Check operation of printer

NO.	ALARM	CAUSE	SOLUTION
A050	SEALING BAR: DRIVE ERROR	An error has been detected on the servo drive	Observe the error code on the servo drive and Contact the technical service.
A054	SEALING BAR: MOVEMENT TIMEOUT	A problem occurred during the sealing phase	Contact the technical assistance service.
A055	SEALING BAR: OBSTACLE PRESENT	The sealing bar has encountered an obstacle during its movement.	<ul style="list-style-type: none"> Remove the obstacle Press RESET on the display on the alarm page.
A073	DOWNSTREAM LINE: NO LINE CONSENT	No downstream line consent for outfeed belt (additional belt at machine outfeed).	<ul style="list-style-type: none"> Go to the OPTIONAL menu and enable the downstream line consent (set to ON) Press RESET on the display on the alarm page.
		In the "OPTIONAL" menu, the downstream line consent is enabled (ON), but the optional is not installed.	Install the unloading belt correctly.

PRECAUTIONS AND SETTING TO MAINTENANCE MODE

	<p>CAUTION!</p> <ul style="list-style-type: none"> • Maintenance must be performed exclusively by skilled personnel familiar with the machine. • Never carry out maintenance, lubrication, or repairs when the machine is in operation and/or connected to the power supply. • Never carry out maintenance on moving parts. • After each operation re-mount any guards that have been removed, and bring the machine back to its original state. • Always observe all safety standards as specified in this manual and these currently applied in the country of installation.
---	--

SETTING THE MACHINE TO THE MAINTENANCE MODE

This procedure must be performed before all routine maintenance, cleaning and special maintenance to shut off the machine from all power sources, as follows:

- Switch the machine off by rotating the main switch (Q1) to "0" (OFF)
- Remove the plug from the main socket
- Wait 15 minutes to allow the capacitors to discharge.

MAINTENANCE TABLE ROUTINE MAINTENANCE PLAN

This type of machine is designed for minimal maintenance; however always observe Maintenance Schedule set out below.

Frequency	Component	Operation
Every Day	Machine	Remove any residues left by the products being processed, which could affect correct machine operation. It is recommended to use compressed air.
Every Day	Photocell, Sensors and Reflector	Clean with soft cloths.
Every Day	Blades	Use cloths or paper to clean the surface that comes in contact with the film. Do not use objects that could damage their surface.
Every Month	Infeed and Sealing Belts	Check alignment and tension.
Every Month	Blades and Contrast bars	Check the wear status of the Teflon adhesive and the silicone strip.
Every 12 Months	Belt Supports	Lubricate with high-viscosity grease for high temperatures (e.g.: SKF LGHB 2 or similar).
Every 12 Months	Gear Couplings	Check for the presence of lubricating grease.

MAINTENANCE PLAN OF SAFETY DEVICES

The periodical control of the “SAFETY DEVICES” listed in the table is required.

Frequency	Component	Operation
Every Month	Front and Rear Guards	<ul style="list-style-type: none"> Opening of front guards (C1) and rear guards (C2) and (C3) guards, both in manual and automatic mode Check the consequences: Luminous and acoustic alarm, the machine blocks.
Every Month	Sealing Bar Protections	<ul style="list-style-type: none"> Movement of guards placed around the sealing bar near the four sensors, in manual mode Check the consequences: - Luminous and acoustic alarm, the machine blocks.
Every Month	Emergency Button	<ul style="list-style-type: none"> Activation of emergency button in manual and automatic mode Check the consequences: - Luminous and acoustic alarm, the machine blocks.

Record of Control

Each control of the safety devices must be recorded, Indicating the data and result of the control performed: Date of Check, Inspector, Result.

Reporting Fault

Should a fault be detected, Contact the Assistance Service of the supplier for its restoration.

DISASSEMBLING, DEMOLITION AND ELIMINATION OF RESIDUALS

	<p>ATTENTION!</p> <p><i>All disassembling and demolition operations must be done by qualified personnel with mechanical and electrical expertise required to work in safe conditions.</i></p>
---	--

Proceed as Follows:

- Disconnect machine from power
- Disassemble Components

All wastes must be treated, eliminated or recycled according to their classification and to the procedures in force established by the laws in force in the country where the equipment has been installed.

	<p><i>The symbol indicates that this product shall not be treated as household waste. By making sure that the product will be properly disposed of, you will facilitate the prevention of potential negative effects for the environment and human health, which might be otherwise caused by the improper waste treatment of this product. For more detailed information about the recycling of this product, please contact the product seller or, as an alternative, the after-sales service or the corresponding waste treatment service.</i></p>
---	--

HEATSEAL with minipack®

