

REVISION HISTORY				
REV	ECN	DATE	BY	DESCRIPTION
1	3146	9/2/2015	KAB	REPLACED TERMINALS, ITEMS 3 & 4
2	3596	4/12/2017	MJA	MOTOR WAS 1839-070

RUN GROUND WIRE (16 AWG GREEN) IN TANDEM WITH MOTOR CABLE. ZIP TIE TO HOLD IN PLACE.

DETAIL A

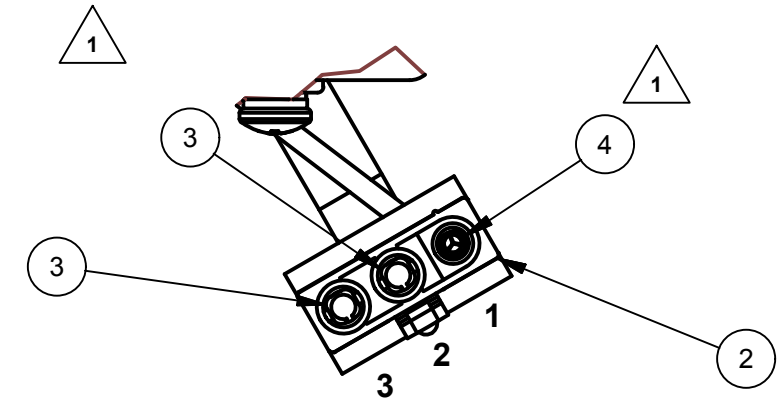
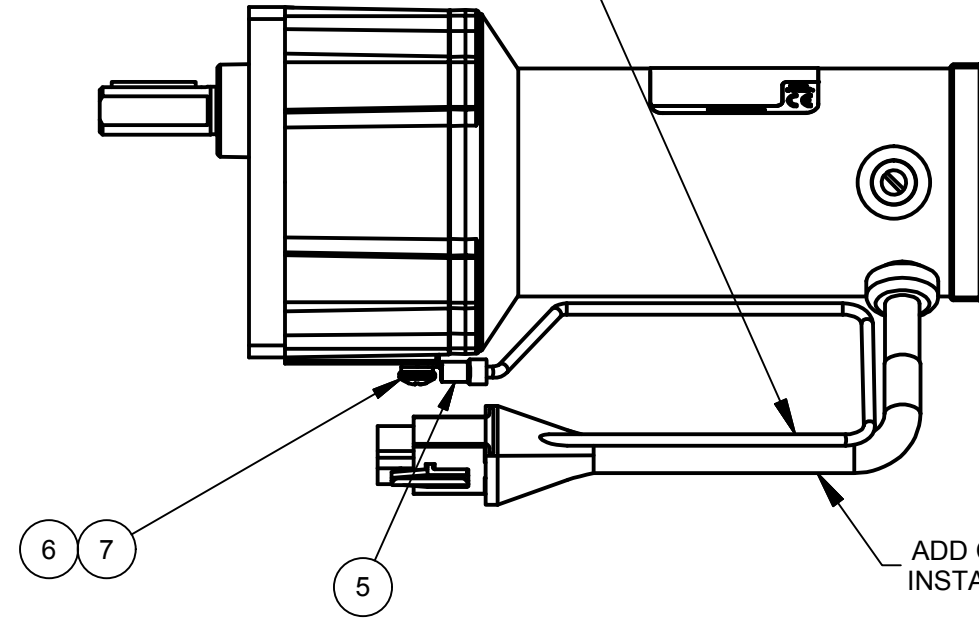
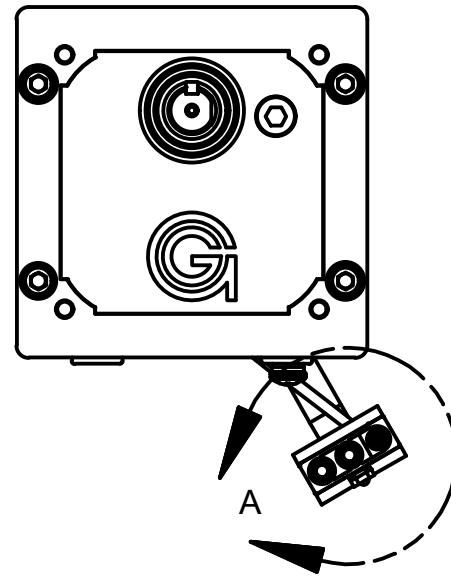

ADD CONNECTOR TO END OF MOTOR WIRE, DO NOT CUT SHORT
INSTALL HEAT SHRINK AROUND CONNECTOR AND MOTOR CABLE

CONNECTOR

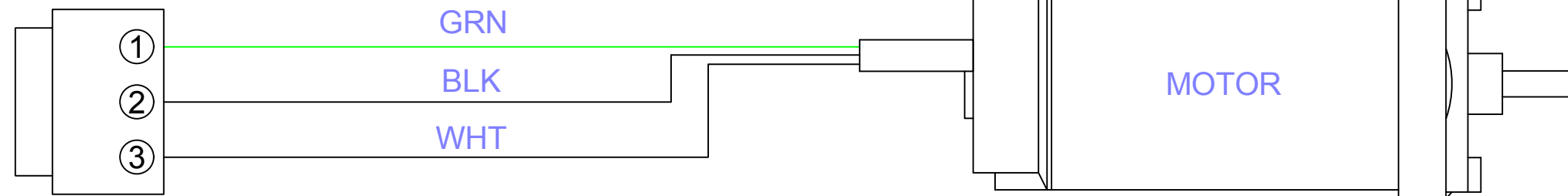

7	1	1903-719	SCR, PAN HD, PHIL, SS, 10-32 X 3/8 LG.
6	1	1907-005	Lockwasher, Split, #10 Med, SS
5	1	1878-012	RING TERMINAL, INSULATED, 16-14 AWG
4	1	1878-071	TERMINAL, CONNECTOR, MALE
3	2	1878-070	TERMINAL, FEMALE
2	1	1875-045	PLUG, 3 PIN, NYLON
1	1	1839-122	GEARMOTOR, 90VDC, 55.6 RPM, 52.2 IN-LBS, 55 WATT
ITEM	QTY	PART NUMBER	DESCRIPTION

NOTE: IF THIS ASSEMBLY IS A REPLACEMENT FOR A HDX250/350 MACHINE WITH THE 1839-070 MOTOR A PROGRAM CHANGE MAY BE NEEDED TO IMPROVE SPEED CONTROL

Material Specification			
HEAT SEAL/AMPAK			
CLEVELAND, OHIO 44125			
CONFIDENTIAL THIS PRINT IS PROPERTY OF, AND DISCLOSES PROPRIETARY INFORMATION OF HEAT SEAL. IT IS LOANED FOR REFERENCE ONLY, AND MAY NOT BE REPRODUCED OR FORWARDED ELECTRONICALLY IN ANY MANNER, OR ITS CONTENTS DISCLOSED TO OTHERS, WITHOUT THE EXPLICIT WRITTEN PERMISSION OF OWNER AND MUST BE DESTROYED UPON REQUEST.	UNLESS OTHERWISE SPECIFIED:	CREATED: 4/30/2015	DESCRIPTION: MOTOR ASSY, HDX TUNNEL CONVEYOR
	ALL DIMENSIONS IN INCHES	CREATED BY: MAbbott	DRAWING NUMBER: 5820-438
	STANDARD TOLERANCES:	CHECKED: 4/30/2015	REVISION: 2
	0.00: ± .010 0.000: ± .005 ANGLE: ± 1'	CHECKED BY: JFEASTER	SIZE: B SCALE: NONE SHEET: 1 OF: 1